

2-Channel PMBus Power System Manager Featuring Programmable Power Good Outputs

FEATURES

- **Sequence, Trim, Margin and Supervise Two Power Supplies**
- **Manage Faults, Monitor Telemetry**
- **PMBus Compliant Command Set**
- **Supported by LTpowerPlay® GUI**
- **Margin or Trim Supplies to Within 0.25% of Target**
- **Monitor Input Current ($\pm 1\%$) and Accumulate Energy**
- **Fast OV/UV Supervisors per Channel**
- **Coordinate Sequencing and Fault Management Across Multiple ADI PSM Devices**
- **Automatic Fault Logging to Internal EEPROM**
- **Operate Autonomously Without Additional Software**
- **Configurable Power Good Output Pins**
- **Accurate Monitoring of Output Voltage, Output Current, Temperature, and Input Voltage and Current**
- **1.8V to 3.3V I²C/SMBus Serial Interface**
- **Connect Directly to Regulator IMON Pins**
- **Can Be Powered from 3.3V, or 4.5V to 15V**
- **Available in 44-Pin 6mm × 7mm QFN Package**

APPLICATIONS

- **Computers and Network Servers**
- **Industrial Test and Measurement**
- **High Reliability Systems**
- **Video and Medical Imaging**

DESCRIPTION

The **LTC®2972** is a 2-channel Power System Manager used to sequence, trim (servo), margin, supervise, manage faults, provide telemetry and create fault logs. PMBus commands support power supply sequencing, precision point-of-load voltage adjustment and margining. DACs use a proprietary soft-connect algorithm to minimize supply disturbances. Supervisory functions include over and under voltage and temperature threshold limits for two power supply output channels as well as over and under voltage threshold limits for a single power supply input channel. Programmable fault responses can disable the power supplies with optional retry after a fault is detected. Faults that disable a power supply can automatically trigger black box EEPROM storage of fault status and associated telemetry. An internal 16-bit ADC monitors two output voltages, two output currents, two external temperatures, input voltage and current, and die temperature. Input power, energy, and output power are also calculated. A programmable watchdog timer monitors microprocessor activity for a stalled condition and resets the microprocessor if necessary. A single wire bus synchronizes power supplies across multiple ADI Power System Management (PSM) devices. Configuration EEPROM with ECC supports autonomous operation without additional software.

All registered trademarks and trademarks are the property of their respective owners. Protected by U.S. Patents including 7382303, 7420359, 8648623 and 8920026.

TYPICAL APPLICATION

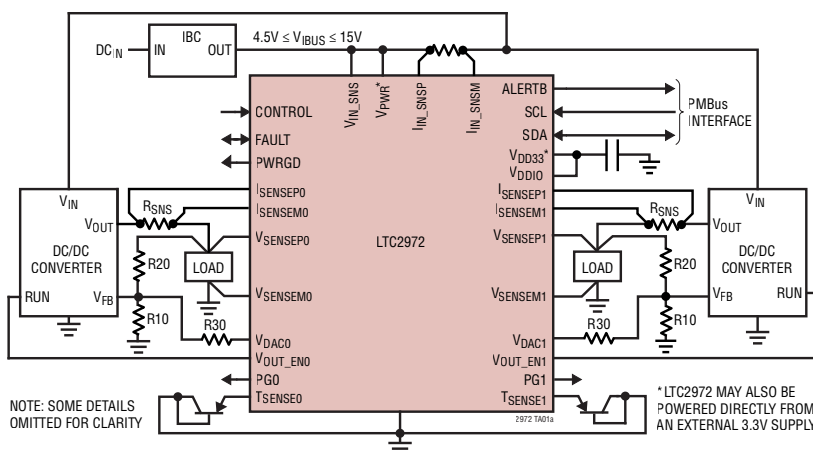

Closed-Loop Servo Error vs Temperature

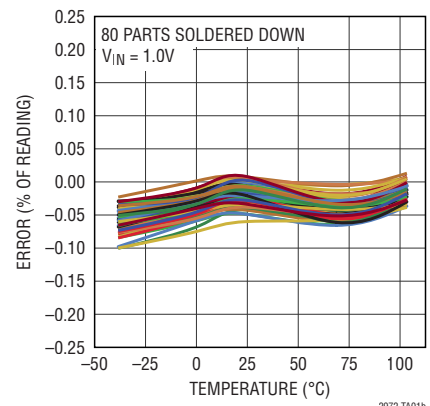

TABLE OF CONTENTS

Features	1	VIN_ON, VIN_OFF, VIN_OV_FAULT_LIMIT, VIN_OV_WARN_	
Applications	1	LIMIT, VIN_UV_WARN_LIMIT and	
Typical Application	1	VIN_UV_FAULT_LIMIT	49
Description	1	INPUT Current and ENERGY	49
Absolute Maximum Ratings	4	Energy Measurement and Reporting	49
Order Information	4	MFR_EIN	49
Pin Configuration	4	MFR_EIN_CONFIG	50
Electrical Characteristics	5	MFR_IIN_CAL_GAIN	51
PMBus Timing Diagram	11	MFR_IIN_CAL_GAIN_TC	51
Typical Performance Characteristics	12	MFR_CLEAR_ENERGY	51
Pin Functions	16	Output Voltage Commands and Limits	52
Block Diagram	18	VOUT_MODE	52
Operation	19	VOUT_COMMAND, VOUT_MAX, VOUT_MARGIN_HIGH, VOUT_	
LTC2972 Operation Overview	19	MARGIN_LOW, VOUT_OV_FAULT_LIMIT,	
EEPROM	20	VOUT_OV_WARN_LIMIT, VOUT_UV_WARN_LIMIT, VOUT_UV_	
AUXFAULTB	20	FAULT_LIMIT, POWER_GOOD_ON and	
RESETB	20	POWER_GOOD_OFF	53
V _{DDIO}	20	MFR_VOUT_DISCHARGE_THRESHOLD	53
PMBus Serial Digital Interface	21	MFR_DAC_STARTUP	53
PMBus	21	MFR_DAC	53
Device Address	21	Output CURRENT Commands and Limits	54
Processing Commands	21	IOUT_CAL_GAIN and IOUT_CAL_OFFSET	54
Addressing and Write Protect	31	IOUT_OC_WARN_LIMIT	54
PAGE	31	MFR_IOUT_CAL_GAIN_TC	54
WRITE_PROTECT	32	External Temperature Commands and Limits	55
WRITE PROTECT Pin	32	OT_FAULT_LIMIT, OT_WARN_LIMIT, UT_WARN_LIMIT and	
MFR_PAGE_FF_MASK	33	UT_FAULT_LIMIT	56
MFR_I2C_BASE_ADDRESS	33	MFR_TEMP_1_GAIN and MFR_TEMP_1_OFFSET	56
MFR_COMMAND_PLUS	33	MFR_T_SELF_HEAT, MFR_IOUT_CAL_GAIN_TAU_INV and MFR_	
MFR_DATA_PLUS0 and MFR_DATA_PLUS1	33	IOUT_CAL_GAIN_THETA	56
MFR_STATUS_PLUS0, and MFR_STATUS_PLUS1	33	Sequencing Timing Limits and Clock Sharing	58
Reading Fault Log Using Command Plus and MFR_DATA_PLUS0 .	34	TON_DELAY, TON_RISE, TON_MAX_FAULT_LIMIT and TOFF_	
Reading Energy Using MFR_COMMAND_PLUS and MFR_DATA_		DELAY	58
PLUS0	35	MFR_RESTART_DELAY	59
Peek Operation Using MFR_DATA_PLUS0	35	Clock Sharing	59
Enabling and Disabling Poke Operations	35	Watchdog Timer and Power Good	59
Poke Operation Using Mfr_data_plus0	36	MFR_PG_CONFIG	60
Command Plus Operations Using MFR_DATA_PLUS1	36	MFR_PG_GPO	62
On/Off Control, Margining and Configuration	36	MFR_PWRGD_EN	62
OPERATION	37	MFR_POWERGOOD_ASSERTION_DELAY	62
ON_OFF_CONFIG	38	Watchdog Operation	63
MFR_CONFIG_LTC2972	38	MFR_WATCHDOG_T_FIRST and MFR_WATCHDOG_T	63
Cascade Sequence ON with Time-Based Sequence OFF	40	Fault Responses	63
MFR_CONFIG2_LTC2972	41	Clearing Latched Faults	64
MFR_CONFIG3_LTC2972	41	VOUT_OV_FAULT_RESPONSE and VOUT_UV_FAULT_RESPONSE	
Tracking Supplies On and Off	42	64	
Tracking Implementation	42	OT_FAULT_RESPONSE, UT_FAULT_RESPONSE, VIN_OV_FAULT_	
MFR_CONFIG_ALL_LTC2972	44	RESPONSE and VIN_UV_FAULT_RESPONSE	65
Programming User EEPROM Space	46	TON_MAX_FAULT_RESPONSE	65
STORE_USER_ALL and RESTORE_USER_ALL	46	MFR_RETRY_DELAY	66
MFR_EE_UNLOCK	47	MR_RETRY_COUNT	66
MFR_EE_ERASE	47	Shared External Faults	67
MFR_EE_DATA	47	MFR_FAULTB0_PROPAGATE and MFR_FAULTB1_PROPAGATE	
Response When Part Is Busy	48	MFR_FAULTB0_RESPONSE and MFR_FAULTB1_RESPONSE ...	67
MFR_EE Erase and Write Programming Time	48	Fault Warning and Status	68
Input Voltage Commands and Limits	48	CLEAR_FAULTS	68

TABLE OF CONTENTS

STATUS_BYTE	69	Servo Modes	93
STATUS_WORD	69	DAC Modes	93
STATUS_VOUT	70	Margining	94
STATUS_IOUT	70	Off Sequencing	94
STATUS_INPUT	70	V _{OUT} Off Threshold Voltage	94
STATUS_TEMPERATURE	71	Automatic Restart via MFR_RESTART_DELAY Command and CONTROL Pin	94
STATUS_CML	71	Fault Management	95
STATUS_MFR_SPECIFIC	72	Output Overvoltage and Undervoltage Faults	95
MFR_PADS	72	Output Overvoltage, Undervoltage, and Overcurrent Warnings ..	95
MFR_COMMON	73	Configuring the AUXFAULTB Output	95
MFR_STATUS_2	74	Multi-Channel Fault Management	95
MFR_FIRST_FAULT	74	Interconnect Between Multiple ADI POWER MANAGERS	97
Telemetry	75	Application Circuits	98
READ_VIN	75	Trimming and Margining DC/DC Converters with External Feedback Resistors	98
READ_IIN	75	Four-Step Resistor Selection Procedure for DC/DC Converters with External Feedback Resistors	98
READ_PIN	75	Trimming and Margining DC/DC Converters with a TRIM Pin	99
READ_VOUT	75	Two-Step Resistor and DAC Full-Scale Voltage Selection Procedure for DC/DC Converters with a TRIM Pin	99
READ_IOUT	76	Measuring Output with a Sense Resistor	100
MFR_IIN_PEAK	76	Measuring Output with Inductor DCR	100
READ_TEMPERATURE_2	76	Single Phase Design Example	100
READ_POUT	77	Measuring Multiphase Currents	101
MFR_READ_IOUT	77	Measuring Output Current in Buffered IMON Telemetry Mode ..	101
MFR_IOUT_SENSE_VOLTAGE	78	LT3086 IMON Design Example	101
MFR_VIN_PEAK	78	Anti-Aliasing Filter Considerations	102
MFR_TEMPERATURE_1_MIN	79	Sensing Negative Voltages	102
Fault Logging	79	Connecting the DC1613 USB to I ² C/SMBus/PMBus Controller to the LTC2972 in System	103
Fault Log Operation	79	Accurate DCR Temperature Compensation	105
MFR_FAULT_LOG_STORE	80	LTpowerPlay: An Interactive GUI for Power Managers	106
MFR_FAULT_LOG_RESTORE	80	PCB Assembly and Layout Suggestions	108
MFR_FAULT_LOG_CLEAR	80	Bypass Capacitor Placement	108
MFR_FAULT_LOG_STATUS	80	Exposed Pad Stencil Design	108
MFR_FAULT_LOG	80	PCB Board Layout	108
MFR_FAULT_LOG Read Example	83	Unused ADC Sense Inputs	108
Identification/Information	88	Design Checklist	109
CAPABILITY	88	I ² C	109
PMBUS_REVISION	88	Output Enables	109
MFR_SPECIAL_ID	88	V _{IN} Sense	109
MFR_SPECIAL_LOT	88	Input Current Sense	109
MFR_INFO	89	External Temperature Sense	109
User Scratchpad	89	Logic Signals	109
USER_DATA_00, USER_DATA_01, USER_DATA_02, USER_DATA_03, USER_DATA_04 and MFR_LTC_RESERVED_2	89	Unused Inputs	109
Applications Information	90	DAC Outputs	109
Overview	90	Package Description	110
Powering the LTC2972	90	Revision History	111
Setting Command Register Values	90	Typical Application	112
MEASURING INPUT CURRENT	90	Related Parts	112
MEASURING INPUT VOLTAGE	92		
MEASURING INPUT POWER	92		
Measuring INPUT ENERGY	92		
Sequence, Servo, Margin and Restart Operations	92		
Command Units On or Off	92		
On Sequencing	93		
On State Operation	93		

ABSOLUTE MAXIMUM RATINGS

(Notes 1, 2)

Supply Voltages:

V _{PWR}	-0.3V to 15V
V _{DD33}	-0.3V to 3.6V
V _{DD25}	-0.3V to 2.75V

Digital Input/Output Voltages:

ALERTB, SDA, SCL, CONTROL0, CONTROL1, PG[1:0], V _{DDIO}	-0.3V to 3.6V
PWRGD, SHARE_CLK, WDI/RESETB, WP, FAULTB0, FAULTB1	-0.3V to 3.6V
ASELO, ASEL1	-0.3V to 3.6V

Analog Voltages:

REFP	-0.3V to 1.35V
REFM	-0.3V to 0.3V
V _{IN_SNS} , V _{IN_SNS_CAP}	-0.3V to 15V
I _{IN_SNSP} , I _{IN_SNSM} to V _{IN_SNS}	-0.3V to 0.3V
V _{SENSEP} [1:0]	-0.3V to 6V
V _{SENSEM} [1:0]	-0.3V to 6V
I _{SENSEP} [1:0]	-0.3V to 6V
I _{SENSEM} [1:0]	-0.3V to 6V
V _{OUT_EN} [1:0], AUXFAULTB	-0.3V to 15V
V _{DAC} [1:0]	-0.3V to 6V
T _{SENSE} [1:0]	-0.3V to 3.6V
I _{IN_SNSP} , I _{IN_SNSM}	-0.3V to 15V

Operating Junction Temperature Range:

LTC2972C	0°C to 70°C
LTC2972I	-40°C to 105°C

Storage Temperature Range -65°C to 150°C*

Maximum Junction Temperature 125°C*

*See OPERATION section for detailed EEPROM derating information for junction temperatures in excess of 105°C.

PIN CONFIGURATION

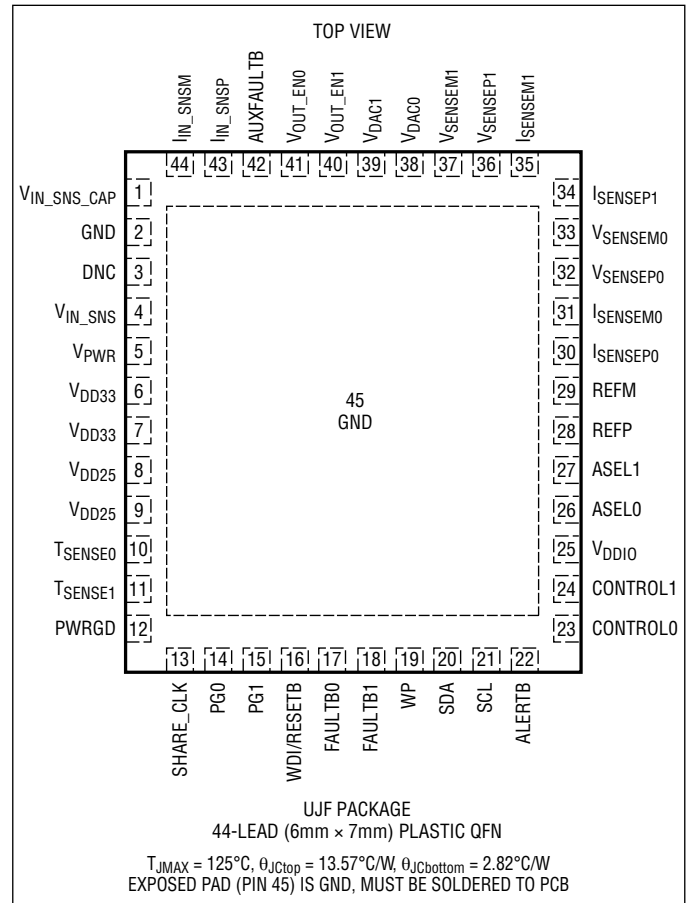

ORDER INFORMATION

TUBE	TAPE AND REEL	PART MARKING*	PACKAGE DESCRIPTION	JUNCTION TEMPERATURE RANGE
LTC2972CUJF#PBF	LTC2972CUJF#TRPBF	LTC2972UJF	44-Lead (6mm × 7mm) Plastic QFN	0°C to 70°C
LTC2972IUJF#PBF	LTC2972IUJF#TRPBF	LTC2972UJF	44-Lead (6mm × 7mm) Plastic QFN	-40°C to 105°C

Contact the factory for parts specified with wider operating temperature ranges. *The temperature grade is identified by a label on the shipping container.

[Tape and reel specifications](#). Some packages are available in 500 unit reels through designated sales channels with #TRMPBF suffix.

ELECTRICAL CHARACTERISTICS The ● denotes the specifications which apply over the full operating temperature range, otherwise specifications are at $T_J = 25^\circ\text{C}$. $V_{PWR} = V_{IN_SNS} = 12\text{V}$, $V_{DD33} = V_{DDIO}$, V_{DD33} , V_{DD25} , REFP and REFM pins floating, unless otherwise indicated. $C_{VDD33} = 100\text{nF}$, $C_{VDD25} = 100\text{nF}$, $C_{VIN_SNS_CAP} = 10\text{nF}$ and $C_{REF} = 100\text{nF}$. (Note 2)

SYMBOL	PARAMETER	CONDITIONS	MIN	TYP	MAX	UNITS
Power Supply Characteristics						
V_{PWR}	V_{PWR} Supply Input Operating Range	V_{DD33} Floating	● 4.5		15	V
I_{PWR}	V_{PWR} Supply Current	$4.5\text{V} \leq V_{PWR} \leq 15\text{V}$, V_{DD33} Floating	●	6.7	9	mA
I_{VDD33}	V_{DD33} Supply Current	$3.13\text{V} \leq V_{DD33} \leq 3.47\text{V}$, $V_{PWR} = V_{DD33}$	●	6.7	9	mA
V_{UVLO_VDD33}	V_{DD33} Undervoltage Lockout	V_{DD33} Ramping Up, $V_{PWR} = V_{DD33}$	● 2.25	2.55	2.8	V
	V_{DD33} Undervoltage Lockout Hysteresis			120		mV
V_{DD33}	Supply Input Operating Range	$V_{PWR} = V_{DD33}$	● 3.13		3.47	V
	Regulator Output Voltage	$4.5\text{V} \leq V_{PWR} \leq 15\text{V}$	● 3.13	3.26	3.47	V
	Regulator Output Short-Circuit Current	$V_{PWR} = 4.5\text{V}$, $V_{DD33} = 0\text{V}$		90		mA
V_{DD25}	Regulator Output Voltage	$3.13\text{V} \leq V_{DD33} \leq 3.47\text{V}$	● 2.35	2.5	2.6	V
	Regulator Output Short-Circuit Current	$V_{PWR} = V_{DD33} = 3.47\text{V}$, $V_{DD25} = 0\text{V}$		55		mA
t_{INIT}	Initialization Time	Time from V_{IN} applied until the TON_DELAY Timer Starts		30		ms
V_{DDIO}	V_{DDIO} Input Operating Range		● 1.62		3.6	V
R_{IN}	V_{DDIO} Input Resistance	$0 \leq V_{VDDIO} \leq 3.6\text{V}$	● 53	68.8	86	k Ω
Voltage Reference Characteristics						
V_{REF}	Output Voltage (Note 3)	$V_{REF} = V_{REFP} - V_{REFM}$, $0 < I_{REFP} < 100\mu\text{A}$	● 1.216	1.228	1.240	V
	Temperature Coefficient			3		ppm/ $^\circ\text{C}$
	Hysteresis	(Note 4)		100		ppm
ADC Characteristics						
V_{IN_ADC}	Voltage Sense Input Range	Differential Voltage: $V_{IN_ADC} = (V_{SENSEPN} - V_{SENSEMN})$	● 0		6	V
		Single-Ended Voltage: $V_{SENSEMN}$	● -0.1		0.1	V
	Current Sense Input Range	Single-Ended Voltage: $I_{SENSEPN}$, $I_{SENSEMN}$	● -0.1		6	V
		Differential Current Sense Voltage: $V_{IN_ADC} = (I_{SENSEPN} - I_{SENSEMN})$ Mfr_config_imon_sel = 0 Mfr_config_imon_sel = 1	● -170 ● -0.1		170 6	mV V
N_ADC	Voltage Sense Resolution	$0\text{V} \leq V_{IN_ADC} \leq 6\text{V}$, READ_VOUT		122		$\mu\text{V}/\text{LSB}$
	Current Sense Resolution with IOUT_CAL_GAIN = 1 Ω	$0\text{mV} \leq V_{IN_ADC} < 16\text{mV}$ (Note 5)		15.625		$\mu\text{A}/\text{LSB}$
		$16\text{mV} \leq V_{IN_ADC} < 32\text{mV}$		31.25		$\mu\text{A}/\text{LSB}$
		$32\text{mV} \leq V_{IN_ADC} < 63.9\text{mV}$		62.5		$\mu\text{A}/\text{LSB}$
		$63.9\text{mV} \leq V_{IN_ADC} < 127.9\text{mV}$		125		$\mu\text{A}/\text{LSB}$
$127.9\text{mV} \leq V_{IN_ADC} $		250		$\mu\text{A}/\text{LSB}$		
$TUE_ADC_VOLT_SNS$	Total Unadjusted Error (Note 3)	Voltage Sense Inputs $V_{IN_ADC} \geq 1\text{V}$	●		± 0.25	% of Reading
		Voltage Sense Inputs $0 \leq V_{IN_ADC} \leq 1\text{V}$	●		± 2.5	mV

ELECTRICAL CHARACTERISTICS The ● denotes the specifications which apply over the full operating temperature range, otherwise specifications are at $T_J = 25^\circ\text{C}$. $V_{PWR} = V_{IN_SNS} = 12\text{V}$, $V_{DD33} = V_{DD10}, V_{DD33}, V_{DD25}, REFP$ and $REFM$ pins floating, unless otherwise indicated. $C_{VDD33} = 100\text{nF}$, $C_{VDD25} = 100\text{nF}$, $C_{VIN_SNS_CAP} = 10\text{nF}$ and $C_{REF} = 100\text{nF}$. (Note 2)

SYMBOL	PARAMETER	CONDITIONS	MIN	TYP	MAX	UNITS
TUE_ADC_CURR_SNS	Total Unadjusted Error (Note 3)	Current Sense Inputs $20\text{mV} \leq V_{IN_ADC} \leq 170\text{mV}$ Mfr_config_imon_sel = 0	●		±0.3	% of Reading
		Current Sense Inputs $ V_{IN_ADC} \leq 20\text{mV}$ Mfr_config_imon_sel = 0	●		±60	μV
		Current Sense Inputs $V_{IN_ADC} \geq 1\text{V}$ Mfr_config_imon_sel = 1	●		±0.25	% of Reading
		Current Sense Inputs $0 \leq V_{IN_ADC} \leq 1\text{V}$ Mfr_config_imon_sel = 1	●		±2.5	mV
V _{OS_ADC}	Offset Error	I _{SENSEPN} and I _{SENSEMN} Inputs, V _{OS} • IOUT_CAL_GAIN, IOUT_CAL_GAIN = 1000mΩ Mfr_config_imon_sel = 0	●		±35	μV
t _{CONV_ADC}	Conversion Time	V _{SENSEPN} , V _{SENSEMN} , V _{IN_SNS} Inputs (Note 6)		6.15		ms
		I _{SENSEPN} and I _{SENSEMN} Inputs (Note 6) Mfr_config_imon_sel = 0		24.6		ms
		I _{SENSEPN} and I _{SENSEMN} Inputs (Note 6) Mfr_config_imon_sel = 1		6.15		ms
		Internal Temperature (READ_TEMPERATURE_2) (Note 6)		24.6		ms
t _{UPDATE_ADC}	Update Time	Mfr_ein_config_hd = 0 (Note 6)		135		ms
		Mfr_ein_config_hd = 1 (Note 6)		305		ms
f _{IN_ADC}	Input Sampling Frequency			62.5		kHz

Sense Input Current Characteristics (Note 7)

I _{IN_VSENSE}	Input Current	V _{SENSEPN} and V _{SENSEMN} Inputs	●		±15	μA
	Differential Input Current	V _{SENSEPN} and V _{SENSEMN} Inputs, V _{IN_DIFF} = 6V	●		±30	μA
I _{IN_ISENSE}	Input Current	I _{SENSEPN} and I _{SENSEMN} Inputs Mfr_config_imon_sel = 0	●		±1	μA
		I _{SENSEPN} and I _{SENSEMN} Inputs Mfr_config_imon_sel = 1	●		±6	μA
	Differential Input Current	I _{SENSEPN} and I _{SENSEMN} Inputs, V _{IN_DIFF} = 170mV Mfr_config_imon_sel = 0	●		±1	μA
		I _{SENSEPN} and I _{SENSEMN} Inputs, V _{IN_DIFF} = 6.0V Mfr_config_imon_sel = 1	●		±12	μA

DAC Output Characteristics

N_VDAC	Resolution			10		Bits		
V _{FS_VDAC}	Full-Scale Output Voltage (Programmable)	DAC Code = 0x3FF	Buffer Gain Setting_0	●	1.3	1.38	1.44	V
		DAC Polarity = 1	Buffer Gain Setting_1	●	2.5	2.65	2.77	V
INL_VDAC	Integral Nonlinearity	(Note 8)	●		±2		LSB	
DNL_VDAC	Differential Nonlinearity	(Note 8)	●		±2.4		LSB	
V _{OS_VDAC}	Offset Voltage	(Note 8)	●		±10		mV	
V _{DAC}	Load Regulation	V _{DACn} = 2.65V, I _{VDACn} Sourcing = 2mA			100		ppm/mA	
		V _{DACn} = 0.1V, I _{VDACn} Sinking = 2mA			100		ppm/mA	
	PSRR	DC: 3.13V ≤ V _{DD33} ≤ 3.47V, V _{PWR} = V _{DD33}			60		dB	
	Leakage Current	V _{DACn} Hi-Z, 0V ≤ V _{DACn} ≤ 6V	●			±100	nA	
	Short-Circuit Current Low	V _{DACn} Shorted to GND	●	-12		-4	mA	
	Short-Circuit Current High	V _{DACn} Shorted to V _{DD33}	●	4		12	mA	

ELECTRICAL CHARACTERISTICS The ● denotes the specifications which apply over the full operating temperature range, otherwise specifications are at $T_J = 25^\circ\text{C}$. $V_{PWR} = V_{IN_SNS} = 12\text{V}$, $V_{DD33} = V_{DDIO}$, V_{DD33} , V_{DD25} , REFP and REFM pins floating, unless otherwise indicated. $C_{VDD33} = 100\text{nF}$, $C_{VDD25} = 100\text{nF}$, $C_{VIN_SNS_CAP} = 10\text{nF}$ and $C_{REF} = 100\text{nF}$. (Note 2)

SYMBOL	PARAMETER	CONDITIONS	MIN	TYP	MAX	UNITS	
C_{OUT}	Output Capacitance	V_{DACn} Hi-Z		10		pF	
t_{S_VDAC}	DAC Output Update Rate	Fast Servo Mode		500		μs	
Voltage Supervisor Characteristics							
V_{IN_VS}	Input Voltage Range (Programmable)	$V_{IN_VS} = (V_{SENSEPN} - V_{SENSEMN})$ Low Resolution Mode	●	0	6	V	
		High Resolution Mode	●	0	3.8	V	
		Single-Ended Voltage: $V_{SENSEMN}$	●	-0.1	0.1	V	
N_VS	Voltage Sensing Resolution	0V to 3.8V Range: High Resolution Mode		4		mV/LSB	
		0V to 6V Range: Low Resolution Mode		8		mV/LSB	
TUE_VS	Total Unadjusted Error	$2\text{V} \leq V_{IN_VS} \leq 6\text{V}$, Low Resolution Mode	●		± 1.25	% of Reading	
		$V_{IN_VS} \leq 2\text{V}$, Low Resolution Mode			± 25	mV	
		$1.5\text{V} < V_{IN_VS} \leq 3.8\text{V}$, High Resolution Mode	●		± 1.0	% of Reading	
		$0.8\text{V} \leq V_{IN_VS} \leq 1.5\text{V}$, High Resolution Mode	●		± 1.5	% of Reading	
		$V_{IN_VS} \leq 0.8\text{V}$, High Resolution Mode			± 12	mV	
t_{S_VS}	Update Rate			12.21		μs	
V_{IN_SNS} Input Characteristics							
V_{IN_SNS}	V_{IN_SNS} Input Voltage Range	(Note 9)	●	0	15	V	
I_{VIN_SNS}	V_{IN_SNS} Input Current	$V_{VIN_SNS} = 4.5\text{V}$	●	80	140	200	μA
		$V_{VIN_SNS} = 12\text{V}$	●	150	250	350	μA
		$V_{VIN_SNS} = 15\text{V}$	●	180	300	420	μA
TUE_{VIN_SNS}	V_{IN_ON} , V_{IN_OFF} Threshold Total Unadjusted Error	$4.5\text{V} \leq V_{VIN_SNS} \leq 8\text{V}$	●		± 2.0	% of Reading	
		$V_{VIN_SNS} > 8\text{V}$	●		± 1.0	% of Reading	
TUE_{VIN}	READ_VIN Total Unadjusted Error	$4.5\text{V} \leq V_{VIN_SNS} \leq 15\text{V}$ (Note 9)	●		± 0.5	% of Reading	
DAC Soft-Connect Comparator Characteristics							
V_{OS_CMP}	Offset Voltage	$V_{DACPN} = 0.2\text{V}$	●		± 1	± 18	mV
		$V_{DACPN} = 1.3\text{V}$	●		± 2	± 26	mV
		$V_{DACPN} = 2.65\text{V}$	●		± 3	± 52	mV
Input Current Sense Characteristics							
V_{IIN}	Common Mode Input Range	$V_{IIN_SNSP} = V_{IIN_SNSM}$ (Note 9)	●	4.5	15	V	
I_{IIN}	I_{IIN_SNSP} , I_{IIN_SNSM} Input Current	$V_{IIN_SNSP} = V_{IIN_SNSM} = V_{IIN_SNS}$ (Note 2)	●		0.5	2	μA
FS_IIN	Full-Scale Input Current Sense Voltage Range	Referred to $(V_{IIN_SNSP} - V_{IIN_SNSM})$ High Range	●	-100	100	mV	
		Medium Range	●	-50	50	mV	
		Low Range	●	-20	20	mV	
TUE_IIN	Total Unadjusted Error	$ V_{IIN_SNSP} - V_{IIN_SNSM} = 100\text{mV}$, High Range	●		± 0.6	% of Reading	
		$ V_{IIN_SNSP} - V_{IIN_SNSM} = 50\text{mV}$, Medium Range	●		± 0.65	% of Reading	
		$ V_{IIN_SNSP} - V_{IIN_SNSM} = 20\text{mV}$, Low Range	●		± 0.75	% of Reading	
		$ V_{IIN_SNSP} - V_{IIN_SNSM} = 20\text{mV}$, High Range	●		± 1	% of Reading	
		$ V_{IIN_SNSP} - V_{IIN_SNSM} = 15\text{mV}$, Medium Range	●		± 1	% of Reading	
		$ V_{IIN_SNSP} - V_{IIN_SNSM} = 10\text{mV}$, Low Range	●		± 1	% of Reading	
		$ V_{IIN_SNSP} - V_{IIN_SNSM} = 0\text{mV}$, High Range	●		± 100	μV	
$ V_{IIN_SNSP} - V_{IIN_SNSM} = 0\text{mV}$, Medium Range	●		± 75	μV			
$ V_{IIN_SNSP} - V_{IIN_SNSM} = 0\text{mV}$, Low Range	●		± 50	μV			

ELECTRICAL CHARACTERISTICS The ● denotes the specifications which apply over the full operating temperature range, otherwise specifications are at $T_J = 25^\circ\text{C}$. $V_{PWR} = V_{IN_SNS} = 12\text{V}$, $V_{DD33} = V_{DDIO}$, V_{DD33} , V_{DD25} , REFP and REFM pins floating, unless otherwise indicated. $C_{VDD33} = 100\text{nF}$, $C_{VDD25} = 100\text{nF}$, $C_{VIN_SNS_CAP} = 10\text{nF}$ and $C_{REF} = 100\text{nF}$. (Note 2)

SYMBOL	PARAMETER	CONDITIONS	MIN	TYP	MAX	UNITS
CMRR_IIN	DC CMRR	$4.5\text{V} \leq V_{IIN_SNSP} = V_{IIN_SNS} \leq 15\text{V}$ $ V_{IIN_SNSP} - V_{IIN_SNSM} = 100\text{mV}$ High Range	●	85		dB
	AC CMRR	$V_{IIN_SNSP} = V_{IIN_SNS} = 12\text{V} \pm 100\text{mV}$ $f = 62.5\text{kHz}$		85		dB
t _{CONV_IIN}	Conversion Time			25		ms
t _{UPDATE}	Update Rate			5.4		Hz

External Temperature Sensor Characteristics (READ_TEMPERATURE_1)

t _{CONV_TSENSE}	Conversion Time	For One Channel, (Total Latency for Both Channels Is 2 • 66ms)		66		ms	
I _{TSENSE_HI}	T _{SENSE} High Level Current		●	-90	-64	-40	μA
I _{TSENSE_LOW}	T _{SENSE} Low Level Current		●	-5.5	-4	-2.5	μA
TUE_TS	Total Unadjusted Error	Ideal Diode Assumed			±3	°C	
N_TS	Maximum Ideality Factor	READ_TEMPERATURE_1 = 175°C MFR_TEMP_1_GAIN = 1/N_TS			1.10		

Internal Temperature Sensor Characteristics (READ_TEMPERATURE_2)

TUE_TS2	Total Unadjusted Error			±1		°C
---------	------------------------	--	--	----	--	----

V_{OUT} Enable Output (V_{OUT_EN} [1:0]) Characteristics

I _{VOUT_ENn}	Output Sinking Current	Strong Pull-Down Enabled, $V_{VOUT_ENn} = 0.4\text{V}$	●	3	5	8	mA
		$V_{VOUT_ENn} = 0.4\text{V}$	●	33	50	65	μA
	Output Leakage Current	$0\text{V} \leq V_{VOUT_ENn} \leq 15\text{V}$	●			±20	μA
V _{VOUT_VALID}	Minimum V _{DD33} when V _{OUT_ENn} Valid	$V_{VOUT_ENn} \leq 0.4\text{V}$	●			1.1	V

General Purpose Output (AUXFAULTB) Characteristics

I _{AUXFAULTB}	Output Sinking Current	Strong Pull-Down Enabled, $V_{AUXFAULTB} = 0.4\text{V}$	●	3	5	8	mA
	Output Leakage Current	$0\text{V} \leq V_{AUXFAULTB} \leq 15\text{V}$	●			±20	μA

Energy Meter Characteristics

TUE_ETB	Energy Meter Time-Base Error		●			±1	% of Reading
TUE_PIN	READ_PIN Total Unadjusted Error	$V_{IIN_SNSP} - V_{IIN_SNSM} = 50\text{mV}$, Medium Range	●			±1	% of Reading
TUE_EIN	Energy Meter Total Unadjusted Error	$V_{IIN_SNSP} - V_{IIN_SNSM} = 50\text{mV}$, Medium Range	●			±2	% of Reading

EEPROM Characteristics

Endurance	(Notes 10, 11)	$0^\circ\text{C} < T_J < 85^\circ\text{C}$ During EEPROM Write Operations	●	10,000			Cycles
Retention	(Notes 10, 11)	$T_J < 105^\circ\text{C}$	●	20			Years
t _{MASS_WRITE}	Mass Write Operation Time (Note 12)	STORE_USER_ALL, $0^\circ\text{C} < T_J < 85^\circ\text{C}$ During EEPROM Write Operations	●		200	4100	ms

Digital Inputs SCL, SDA, CONTROL0, CONTROL1, PG0, PG1, WDI/RESETB, FAULTB0, FAULTB1, WP

V _{IH}	Input High Threshold Voltage	$1.62\text{V} \leq V_{VDDIO} \leq 3.6\text{V}$	●	$0.7 \cdot V_{VDDIO}$			V
V _{IL}	Input Low Threshold Voltage	$1.62\text{V} \leq V_{VDDIO} \leq 3.6\text{V}$	●		$0.3 \cdot V_{VDDIO}$		V
V _{HYST}	Input Hysteresis	FAULTB _n , CONTROL _n , PG _n , WDI/RESETB, WP			20		mV
		SDA, SCL			80		mV
I _{LEAK}	Input Leakage Current	$0\text{V} \leq V_{PIN} \leq 3.6\text{V}$	●			±2	μA

ELECTRICAL CHARACTERISTICS The ● denotes the specifications which apply over the full operating temperature range, otherwise specifications are at $T_J = 25^\circ\text{C}$. $V_{PWR} = V_{IN_SNS} = 12\text{V}$, $V_{DD33} = V_{DDIO}$, V_{DD33} , V_{DD25} , REFP and REFM pins floating, unless otherwise indicated. $C_{VDD33} = 100\text{nF}$, $C_{VDD25} = 100\text{nF}$, $C_{VIN_SNS_CAP} = 10\text{nF}$ and $C_{REF} = 100\text{nF}$. (Note 2)

SYMBOL	PARAMETER	CONDITIONS	MIN	TYP	MAX	UNITS
t_{SP}	Pulse Width of Spike Suppressed	FAULTB0, FAULTB1, CONTROL n		10		μs
		SDA, SCL		98		ns
t_{FAULT_MIN}	Minimum Low Pulse Width for Externally Generated Faults		180			ms
t_{RESETB}	Pulse Width to Assert Reset	$V_{WDI/RESETB} \leq 1.5\text{V}$	●	300		μs
t_{WDI}	Pulse Width to Reset Watchdog Timer	$V_{WDI/RESETB} \leq 1.5\text{V}$	●	0.3	200	μs
f_{WDI}	Watchdog Timer Interrupt Input Frequency		●		1	MHz
C_{IN}	Input Capacitance			10		pF

Digital Input SHARE_CLK

V_{IH}	High Level Input Voltage		●	1.6		V
V_{IL}	Low Level Input Voltage		●		0.8	V
$f_{SHARE_CLK_IN}$	Input Frequency Operating Range		●	90	110	kHz
t_{LOW}	Assertion Low Time	$V_{SHARE_CLK} < 0.8\text{V}$	●	0.825	1.11	μs
t_{RISE}	Rise Time	$V_{SHARE_CLK} < 0.8\text{V}$ to $V_{SHARE_CLK} > 1.6\text{V}$	●		450	ns
I_{LEAK}	Input Leakage Current	$0\text{V} \leq V_{SHARE_CLK} \leq V_{DD33} + 0.3\text{V}$	●		± 1	μA
C_{IN}	Input Capacitance			10		pF

Digital Outputs SDA, ALERTB, SHARE_CLK, FAULTB0, FAULTB1, PWRGD, PG0, PG1

V_{OL}	Digital Output Low Voltage	$I_{SINK} = 3\text{mA}$	●		0.4	V
$f_{SHARE_CLK_OUT}$	Output Frequency Operating Range	5.49k Ω Pull-Up to V_{DD33}	●	90	100 110	kHz

Digital Inputs ASELO,ASEL1

V_{IH}	Input High Threshold Voltage		●	$V_{DD33} - 0.5$		V
V_{IL}	Input Low Threshold Voltage		●		0.5	V
$I_{IH,IL}$	High, Low Input Current	$ASEL[1:0] = 0$, V_{DD33}	●		± 95	μA
I_{HIZ}	Hi-Z Input Current		●		± 24	μA
C_{IN}	Input Capacitance			10		pF

Serial Bus Timing Characteristics

f_{SCL}	Serial Clock Frequency (Note 13)		●	10	400	kHz
t_{LOW}	Serial Clock Low Period (Note 13)		●	1.3		μs
t_{HIGH}	Serial Clock High Period (Note 13)		●	0.6		μs
t_{BUF}	Bus Free Time Between Stop and Start (Note 13)		●	1.3		μs
$t_{HD,STA}$	Start Condition Hold Time (Note 13)		●	600		ns
$t_{SU,STA}$	Start Condition Setup Time (Note 13)		●	600		ns
$t_{SU,STO}$	Stop Condition Setup Time (Note 13)		●	600		ns
$t_{HD,DAT}$	Data Hold Time (LTC2972 Receiving Data) (Note 13)		●	0		ns
	Data Hold Time (LTC2972 Transmitting Data) (Note 13)		●	300	900	ns
$t_{SU,DAT}$	Data Setup Time (Note 13)		●	100		ns

ELECTRICAL CHARACTERISTICS The ● denotes the specifications which apply over the full operating temperature range, otherwise specifications are at $T_J = 25^\circ\text{C}$. $V_{PWR} = V_{IN_SNS} = 12\text{V}$, $V_{DD33} = V_{DDIO}$, V_{DD33} , V_{DD25} , REFP and REFM pins floating, unless otherwise indicated. $C_{VDD33} = 100\text{nF}$, $C_{VDD25} = 100\text{nF}$, $C_{VIN_SNS_CAP} = 10\text{nF}$ and $C_{REF} = 100\text{nF}$. (Note 2)

SYMBOL	PARAMETER	CONDITIONS	MIN	TYP	MAX	UNITS
t_{SP}	Pulse Width of Spike Suppressed (Note 13)			98		ns
$t_{TIMEOUT_BUS}$	Time Allowed to Complete any PMBus Command After Which Time SDA Will Be Released and Command Terminated	Mfr_config_all_longer_pmbus_timeout = 0	●	25	35	ms
		Mfr_config_all_longer_pmbus_timeout = 1	●	200	280	ms

Additional Digital Timing Characteristics

SYMBOL	PARAMETER	CONDITIONS	MIN	TYP	MAX	UNITS
t_{OFF_MIN}	Minimum Off-Time for Any Channel			100		ms

Note 1: Stresses beyond those listed under Absolute Maximum Ratings may cause permanent damage to the device. Exposure to any Absolute Maximum Rating condition for extended periods may affect device reliability and lifetime.

Note 2: All currents into device pins are positive. All currents out of device pins are negative. All voltages are referenced to GND unless otherwise specified. If power is supplied to the chip via the V_{DD33} pin only, connect V_{PWR} and V_{DD33} pins together.

Note 3: The ADC total unadjusted error includes all error sources. First, a two-point analog trim is performed to achieve a flat reference voltage (V_{REF}) over temperature. This results in minimal temperature coefficient, but the absolute voltage can still vary. To compensate for this, a high resolution, drift-free, and noiseless digital trim is applied at the output of the ADC, resulting in a very high accuracy measurement.

Note 4: Hysteresis in the output voltage is created by package stress that differs depending on whether IC was previously at a higher or lower temperature. Output voltage is always measured at 25°C , but the IC is cycled to 105°C or -40°C before successive measurements. Hysteresis is roughly proportional to the square of the temperature change.

Note 5: The current sense resolution is determined by the L11 format, the value of $I_{OUT_CAL_GAIN}$, and the magnitude of the current being measured. See Table 5 on page 77 for details.

Note 6: The nominal time between successive ADC conversions (latency of the ADC) for any given channel is t_{UPDATE_ADC} .

Note 7: V_{SENSE} and I_{SENSE} input currents are characterized by input current and input differential current. Input current is defined as current into a single device pin (see Note 2). Input differential current is defined as $(I^+ - I^-)$ where I^+ is the current into the positive device pin and I^- is the current into the negative device pin.

Note 8: Nonlinearity is defined from the first code that is greater than or equal to the maximum offset specification to full-scale code, 1023.

Note 9: While $READ_VIN$ operates with $0\text{V} \leq V_{IN_SNS} \leq 15\text{V}$, the valid $READ_IIN$, $READ_PIN$, and MFR_EIN operating range is $4.5\text{V} \leq V_{IN_SNS} \leq 15\text{V}$.

Note 10: EEPROM endurance and retention are guaranteed by design, characterization and correlation with statistical process controls. The minimum retention specification applies for devices whose EEPROM has been cycled less than the minimum endurance specification.

Note 11: EEPROM endurance and retention will be degraded when $T_J > 105^\circ\text{C}$.

Note 12: The LTC2972 will not acknowledge any PMBus commands, except for MFR_COMMON , when a $STORE_USER_ALL$ command is being executed. See also Operation section.

Note 13: Maximum capacitive load, C_B , for SCL and SDA is 400pF. Data and clock rise time (t_r) and fall time (t_f) are: $(20 + 0.1 \cdot C_B)$ (ns) $< t_r < 300\text{ns}$ and $(20 + 0.1 \cdot C_B)$ (ns) $< t_f < 300\text{ns}$. C_B = capacitance of one bus line in pF. SCL and SDA external pull-up voltage, V_{DDIO} , is $1.35\text{V} < V_{DDIO} < 3.6\text{V}$.

PMBUS TIMING DIAGRAM



TYPICAL PERFORMANCE CHARACTERISTICS

Reference Voltage vs Temperature

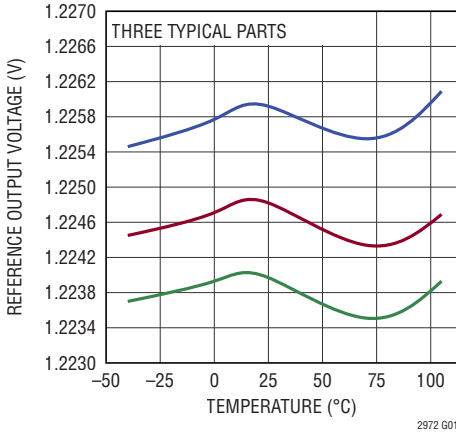

ADC READ_VOUT ADC Total Unadjusted Error vs Temperature

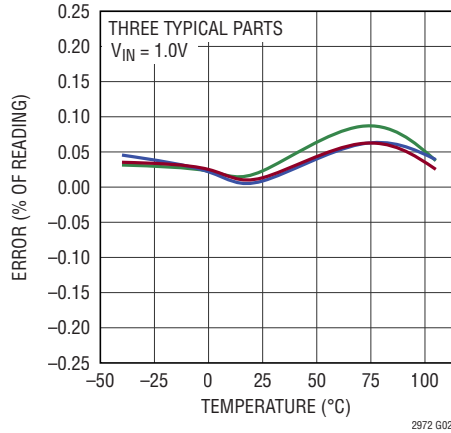

ADC READ_IOUT Input Referred Offset Voltage vs Temperature

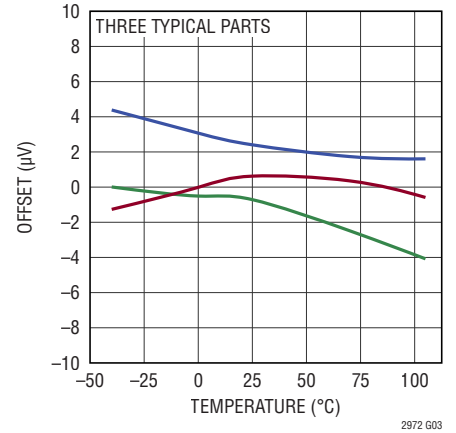

ADC READ_VOUT ADC Total Unadjusted Error vs Input Voltage

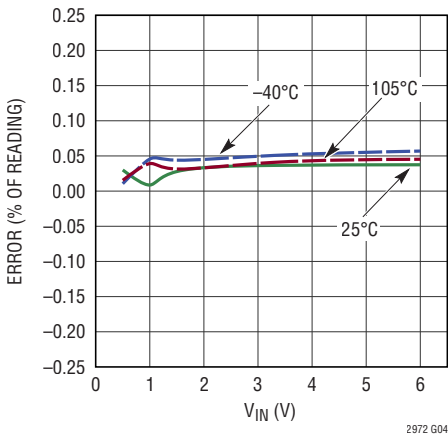

ADC READ_VOUT Noise Histogram

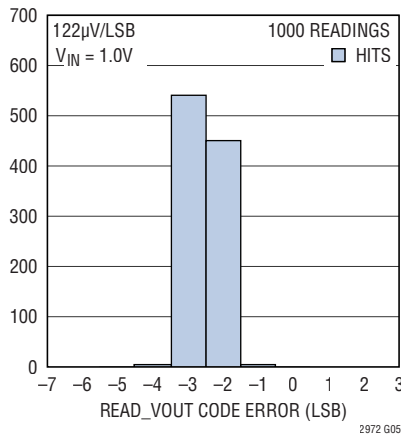

ADC READ_IOUT Error vs READ_IOUT

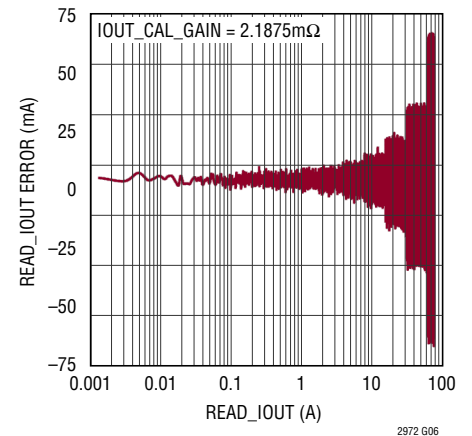

ADC MFR_READ_IOUT ADC Total Unadjusted Error vs Input Voltage

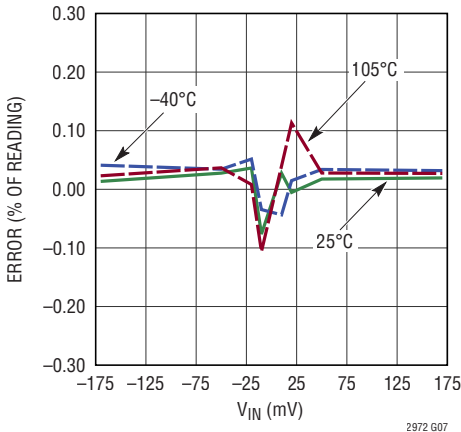

ADC MFR_READ_IOUT Noise Histogram

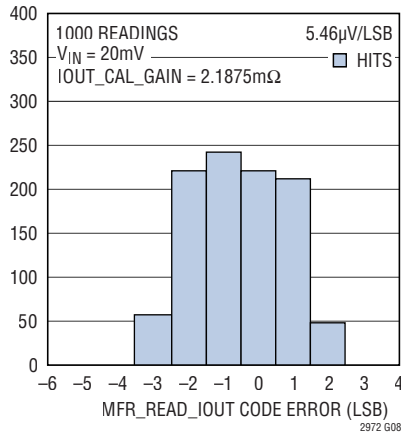

Power Measurement Error

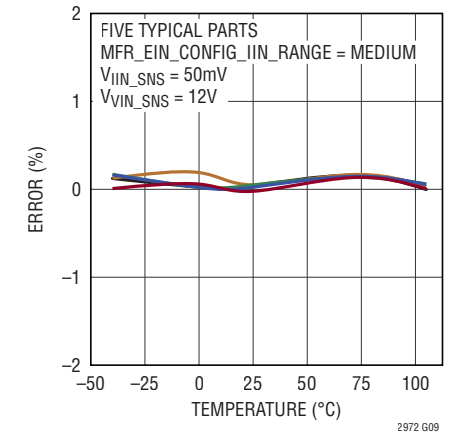

TYPICAL PERFORMANCE CHARACTERISTICS

SHARE_CLK Output Frequency vs Temperature

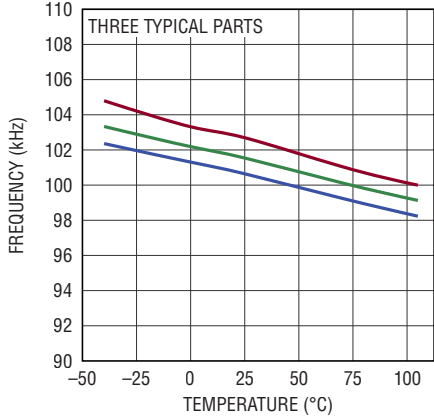

V_{DDIO} Input Resistance vs Temperature

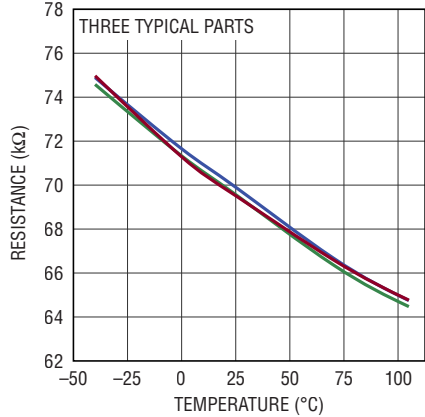

DAC Full-Scale Voltage vs Temperature, Gain Setting = 0

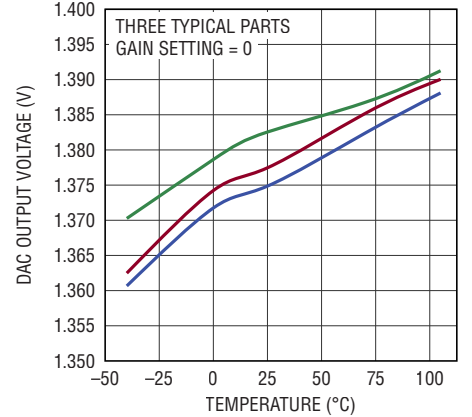

DAC Full-Scale Voltage vs Temperature, Gain Setting = 1

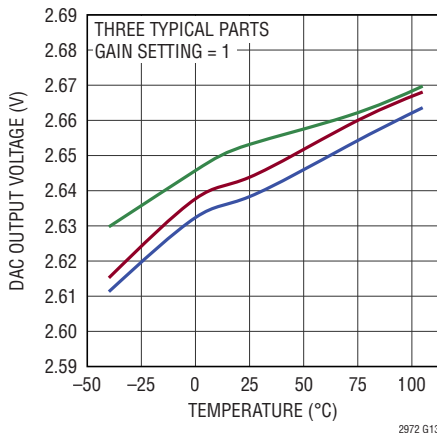

DAC Offset Voltage vs Temperature, Gain Setting = 0

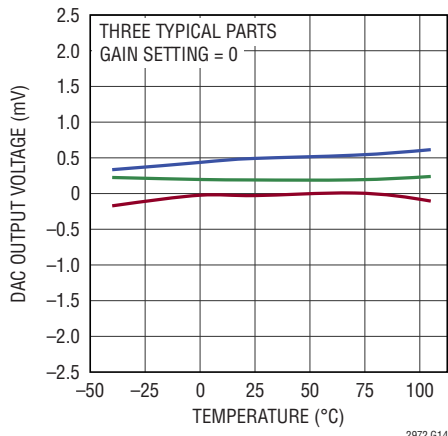

DAC Offset Voltage vs Temperature, Gain Setting = 1

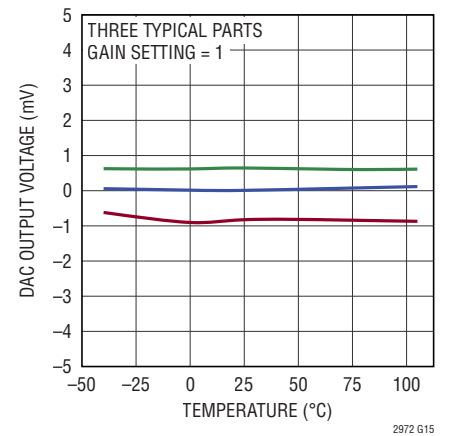

V_{DD25} Regulator Output Voltage vs Temperature

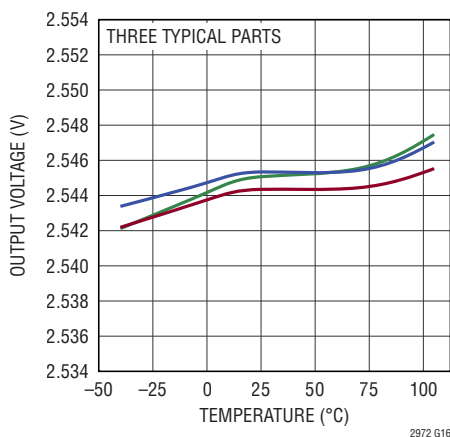

V_{DD33} Regulator Output Voltage vs Temperature

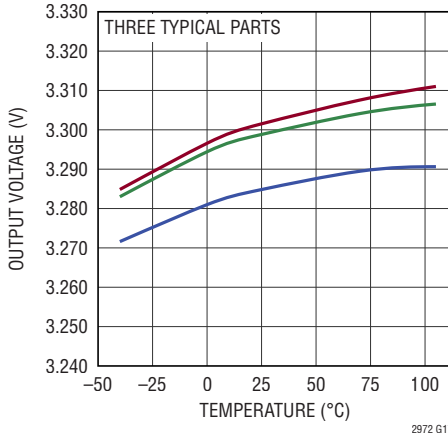

**External Temperature READ_
TEMPERATURE_1 Error vs Temperature**

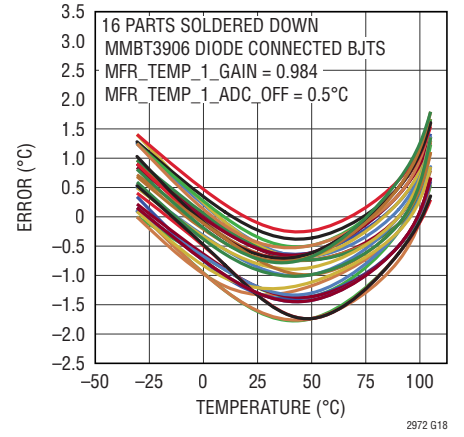

TYPICAL PERFORMANCE CHARACTERISTICS

READ_TEMPERATURE_2 Error vs Temperature

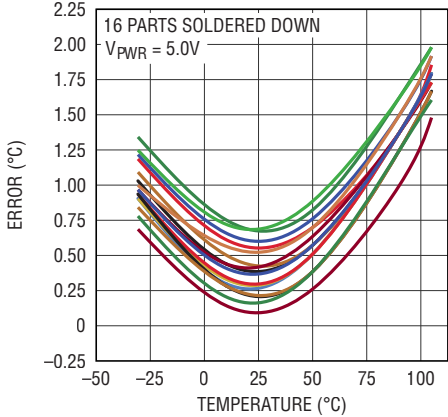

TUE_VIN vs VIN_SNS

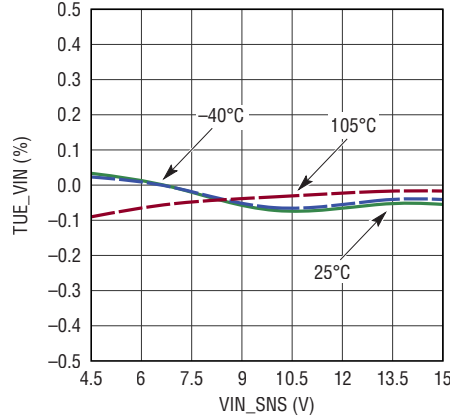

TUE_IIN vs VIN_SNS

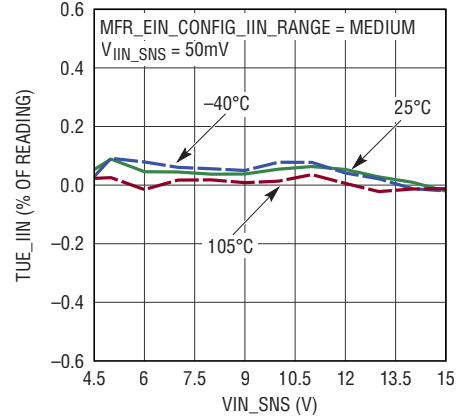

TUE_PIN vs VIN_SNS

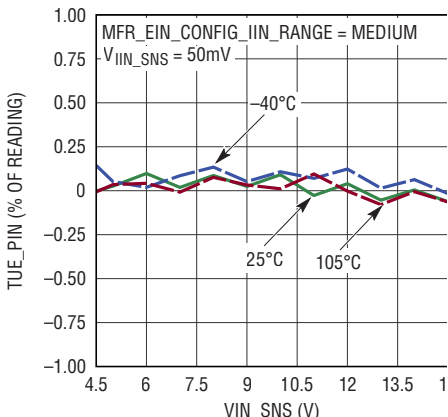

TUE_ETB vs VIN_SNS

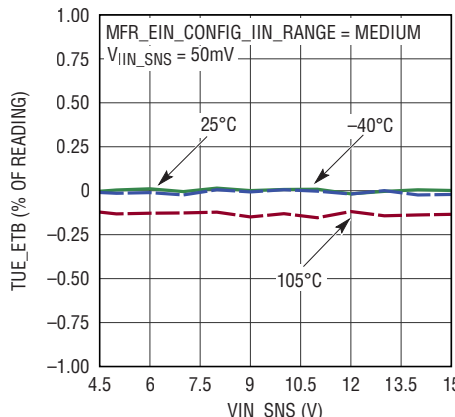

TUE_EIN vs VIN_SNS

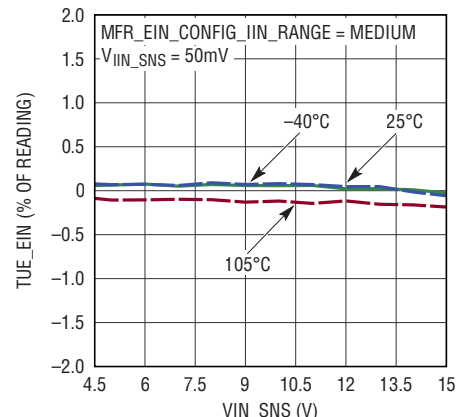

READ_IIN Common Mode Gain vs Frequency

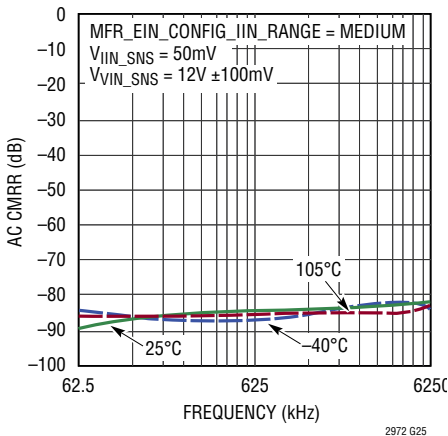

VOUT_EN[0:1] and AUXFAULTB Output High Voltage vs Load Current

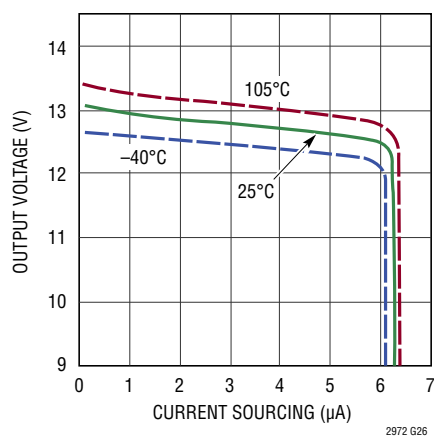

VOUT_EN[0:1] and AUXFAULTB VOL vs Load Current

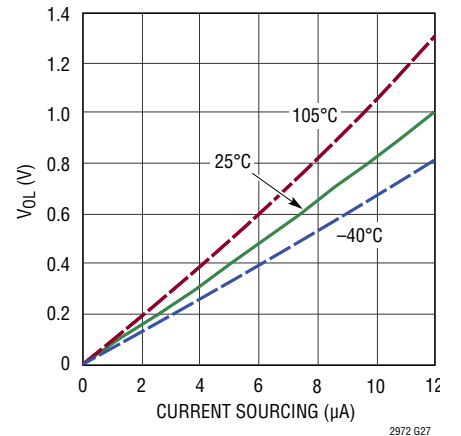

TYPICAL PERFORMANCE CHARACTERISTICS

Voltage Sense Input Currents vs Differential Input Voltage

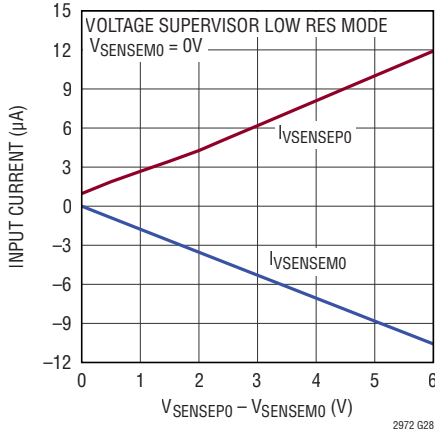

Voltage Sense Differential Input Current vs Differential Input Voltage

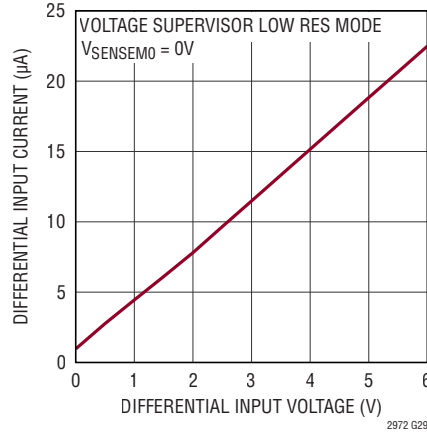

Current Sense Input Currents vs Common Mode Voltage

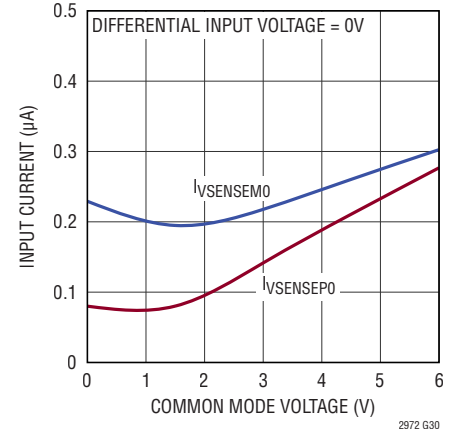

Current Sense Differential Input Current vs Differential Input Voltage

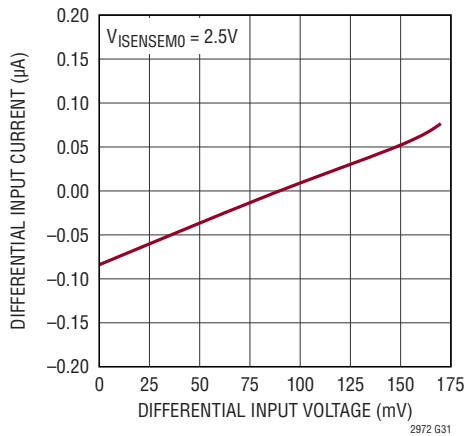

IMON Sense Input Currents vs Differential Input Voltage

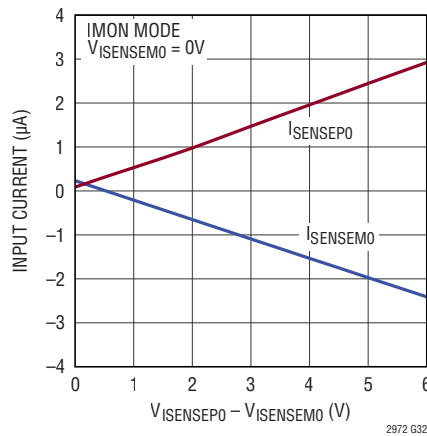

V_{OUT_EN[1:0]} Output Voltage vs V_{DD33}

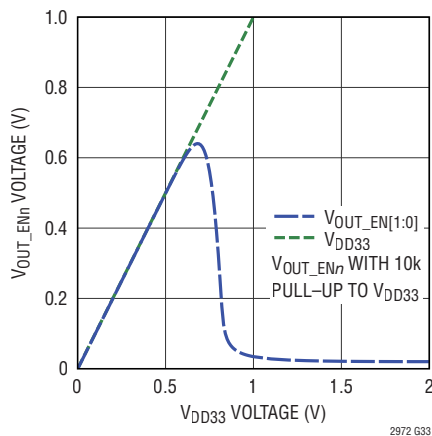

Closed-Loop Servo Error

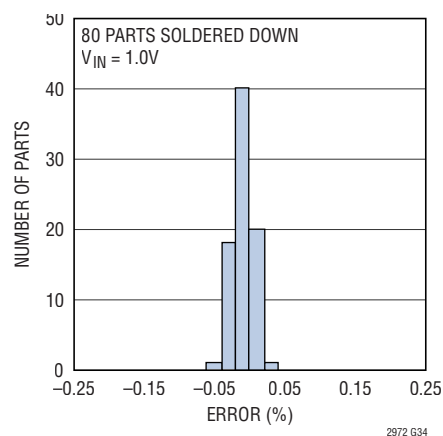

PIN FUNCTIONS

PIN NAME	PIN NUMBER	PIN TYPE	DESCRIPTION
V _{SENSE0}	32*	In	DC/DC Converter Differential (+) Output Voltage-0 Sensing Pin
V _{SENSE0}	33*	In	DC/DC Converter Differential (-) Output Voltage-0 Sensing Pin
V _{OUT_EN0}	41	Out	DC/DC Converter Enable-0 Pin.
V _{OUT_EN1}	40	Out	DC/DC Converter Enable-1 Pin.
AUXFAULTB	42	Out	Auxiliary Fault Output Pin. Can Be Configured to Pull Low When OV/UV Detected
DNC	3	Do Not Connect	Do Not Connect to this Pin
V _{IN_SNS}	4	In	V _{IN} SENSE Input. This Voltage is Compared Against the V _{IN} On and Off Voltage Thresholds In Order to Determine When to Enable and Disable, Respectively, the Downstream DC/DC Converters
V _{PWR}	5	In	V _{PWR} Serves as the Unregulated Power Supply Input to the Chip (4.5 to 15V). If a 4.5V to 15V Supply Voltage Is Unavailable, Short V _{PWR} to V _{DD33} and Power the Chip Directly from a 3.3V Supply. Bypass to GND with 0.1μF Capacitor
V _{DD33}	6	In/Out	If Shorted to V _{PWR} , It Serves as 3.13 to 3.47V Supply Input Pin. Otherwise It Is a 3.3V Internally Regulated Voltage Output (Use 0.1μF Decoupling Capacitor to GND). If using the internal regulator to provide V _{DD33} , only connect the pull-up resistors and bypass capacitors required to support the LTC2972 in the application.
V _{DD33}	7	In	Input for Internal 2.5V Sub-Regulator. Short this Pin to Pin 6. If using the internal regulator to provide V _{DD33} , only connect the pull-up resistors and bypass capacitors required to support the LTC2972 in the application.
V _{DD25}	8	In/Out	2.5V Internally Regulated Voltage Output. Bypass to GND with a 0.1μF Capacitor. Only connect the pull-up resistors and bypass capacitors required to support the LTC2972 in the application.
V _{DD25}	9	In	2.5V Supply Voltage Input. Short this Pin to Pin 8. Only connect the pull-up resistors and bypass capacitors required to support the LTC2972 in the application.
T _{SENSE0}	10*	In/Out	External Temperature Current Output and Voltage Input for Channel 0. Maximum allowed capacitance is 1μF
T _{SENSE1}	11*	In/Out	External Temperature Current Output and Voltage Input for Channel 1. Maximum allowed capacitance is 1μF
PWRGD	12	Out	Power-Good Open Drain Output. Indicates When Selected Outputs Are Power Good. Can be Used as System Power-On Reset
SHARE_CLK	13	In/Out	Bidirectional Clock Sharing Pin. Connect a 5.49kΩ Pull-Up Resistor to V _{DD33} . Connect to all other SHARE_CLK pins in the system
PG0	14	In/Out	Configurable Open-Drain Output and Digital Input for Channel 0. Connect a 10kΩ Pull-Up Resistor to V _{DDIO} .
PG1	15	In/Out	Configurable Open-Drain Output and Digital Input for Channel 1. Connect a 10kΩ Pull-Up Resistor to V _{DDIO} .
WDI/RESETB	16	In	Watchdog Timer Interrupt and Chip Reset Input. Connect a 10kΩ Pull-Up Resistor to V _{DD33} . Rising Edge Resets Watchdog Counter. Holding this Pin Low for More than t _{RESETB} Resets the Chip
FAULTB0	17	In/Out	Open-Drain Output and Digital Input. Active Low Bidirectional Fault Indicator-0. Connect a 10kΩ Pull-Up Resistor to V _{DDIO}
FAULTB1	18	In/Out	Open-Drain Output and Digital Input. Active Low Bidirectional Fault Indicator-1. Connect a 10kΩ Pull-Up Resistor to V _{DDIO}
WP	19	In	Digital Input. Write-Protect Input Pin, Active High
SDA	20	In/Out	PMBus Bidirectional Serial Data Pin
SCL	21	In	PMBus Serial Clock Input Pin (400kHz Maximum)
ALERTB	22	Out	Open-Drain Output. Generates an Interrupt Request in a Fault/Warning Situation
CONTROL0	23	In	Control Pin 0 Input
CONTROL1	24	In	Control Pin 1 Input

PIN FUNCTIONS

PIN NAME	PIN NUMBER	PIN TYPE	DESCRIPTION
V _{DDIO}	25	In	Sets the Input Threshold of all Digital inputs, except SHARE_CLK, ASEL[1:0], VOUT_EN[1:0] and AUX_FAULTB, to approximately 45% of V _{DDIO} . Connect to a supply voltage between 1.5V and 3.6V. Connect all of the LTC2972 pins pull-up resistors to this pin except WDI/RESETB, SHARE_CLK and VOUT_EN[1:0]. Connect these pins pull-up resistors to V _{DD33}
ASEL0	26	In	Ternary Address Select Pin 0 Input. Connect to V _{DD33} , GND or Float to Encode 1 of 3 Logic States
ASEL1	27	In	Ternary Address Select Pin 1 Input. Connect to V _{DD33} , GND or Float to Encode 1 of 3 Logic States
REFP	28	Out	Reference Voltage Output. Needs 0.1μF Decoupling Capacitor to REFM
REFM	29	Out	Reference Return Pin. Needs 0.1μF Decoupling Capacitor to REFP
I _{SENSEPO}	30*	In	DC/DC Converter Differential (+) Output Current-0 Sensing Pin
I _{SENSEM0}	31*	In	DC/DC Converter Differential (-) Output Current-0 Sensing Pin
I _{SENSEP1}	34*	In	DC/DC Converter Differential (+) Output Current-1 Sensing Pin
I _{SENSEM1}	35*	In	DC/DC Converter Differential (-) Output Current-1 Sensing Pin
V _{IN_SNS_CAP}	1	Out	V _{IN_SNS} Filter Capacitor Pin. Bypass to Ground with a 10nF Ceramic Capacitor
GND	2	Ground	
V _{DAC0}	38	Out	DAC0 Output
V _{DAC1}	39	Out	DAC1 Output
I _{IN_SNSP}	43	In	DC/DC Converter Differential (+) Input Current Sensing Pin. If Unused, Connect to V _{IN_SNS}
I _{IN_SNSM}	44	In	DC/DC Converter Differential (-) Input Current Sensing Pin. If Unused, Connect to V _{IN_SNS}
V _{SENSEP1}	36*	In	DC/DC Converter Differential (+) Output Voltage-1 Sensing Pin
V _{SENSEM1}	37*	In	DC/DC Converter Differential (-) Output Voltage-1 Sensing Pin
GND	45	Ground	Exposed Pad. Must Be Soldered to PCB

* Tie any unused V_{SENSEP_n}/I_{SENSEP_n}, V_{SENSEM_n}/I_{SENSEM_n} or T_{SENSE_n} pins to GND. Refer to Unused ADC Sense Inputs in the Applications Information section.

BLOCK DIAGRAM

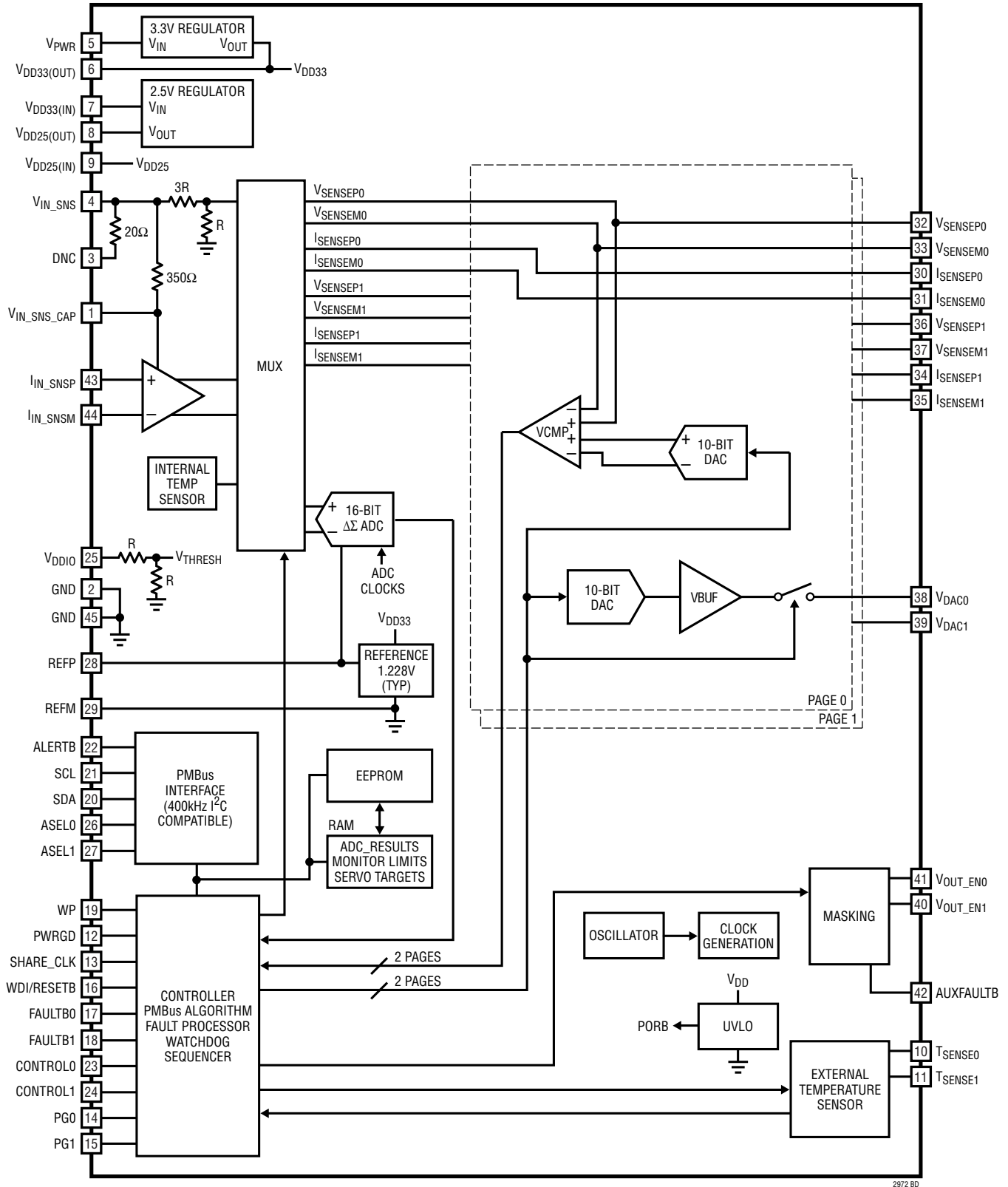

See Figure 34 for a Typical Application with a Simplified Block Diagram

2972 80

OPERATION

LTC2972 OPERATION OVERVIEW

The LTC2972 is a PMBus programmable power supply controller, monitor, sequencer and voltage supervisor that can perform the following operations:

- Accept PMBus compatible programming commands.
- Provide DC/DC converter input voltage, output voltage, output current, output temperature, and LTC2972 internal temperature readback through the PMBus interface.
- Connect directly to a DC/DC converters IMON pin or the DCR sense network for output current telemetry readback.
- Control the output of DC/DC converters that set the output voltage with a trim pin or DC/DC converters that set the output voltage using an external resistor feedback network.
- Sequence the startup of DC/DC converters via PMBus programming and the CONTROL input pins. The LTC2972 supports time-based sequencing and tracking sequencing. Cascade sequence on with time based sequence off is also supported.
- Trim the DC/DC converter output voltage (typically in 0.02% steps), in closed-loop servo operating mode, autonomously or through PMBus programming.
- Margin the DC/DC converter output voltage to PMBus programmed limits.
- Trim or margin the DC/DC converter output voltage with direct access to the margin DAC.
- Supervise the DC/DC converter input voltage, output voltage and the inductor temperatures for overvalue/undervalue conditions with respect to PMBus programmed limits and generate appropriate faults and warnings.
- Accurately handle inductor self-heating transients using a proprietary algorithm. These self-heating effects are combined with external temperature sensor readings to improve accuracy of ADC current measurements.
- Respond to a fault condition by continuing operation indefinitely, latching-off after a programmable deglitch period, latching-off immediately or sequencing off after TOFF_DELAY. Use retry mode to automatically recover from a latched-off condition. With retry enabled, MFR_RETRY_COUNT programs the number of retries (0 to 6 or infinite) for both pages.
- Optionally stop trimming the DC/DC converter output voltage after it reaches the initial margin or nominal target. Optionally allow trimming restart if target drifts outside of V_{OUT} warning limits.
- Store command register contents to EEPROM with CRC and ECC through PMBus programming.
- Restore EEPROM contents through PMBus programming or when V_{DD33} is applied on power-up.
- Generate interrupt requests by asserting the ALERTB pin in response to supported PMBus faults and warnings.
- Coordinate system wide fault responses for all DC/DC converters connected to the LTC2972 FAULTB0 and FAULTB1 pins.
- Propagate per-channel POWER GOOD status via the PG0 and PG1 pins, or configure these pins as general-purpose IOs.
- Synchronize sequencing delays or shutdown for multiple devices using the SHARE_CLK pin.
- Software and hardware write protect the command registers.
- Disable the input voltage to the supervised DC/DC converters in response to output OV and UV faults.
- Log telemetry and status data to EEPROM in response to a faulted-off condition.
- Supervise an external microcontroller's activity for a stalled condition with a programmable watchdog timer and reset it if necessary.
- Prevent a DC/DC converter from re-entering the on state after a power cycle until a programmable interval (MFR_RESTART_DELAY) has elapsed and its output has decayed below a programmable threshold voltage (MFR_VOUT_DISCHARGE_THRESHOLD).
- Read high side input current, input voltage, input power, and accumulated input energy.

OPERATION

- Record minimum and maximum input voltage, input current, input power, output voltages, output currents and output temperatures.
- Access user EEPROM data directly, without altering RAM space (Mfr_ee_unlock, Mfr_ee_erase, and Mfr_ee_data). Facilitates in-house bulk programming.
- Accommodate multiple hosts with Command Plus.

EEPROM

The LTC2972 contains internal EEPROM (Nonvolatile Memory) with error-correcting-code (ECC) to store configuration settings and fault log information. EEPROM endurance, retention and mass write operation time are specified over the operating temperature range. See Electrical Characteristics and Absolute Maximum Ratings sections.

Non-destructive operation above $T_J = 105^\circ\text{C}$ is possible although the Electrical Characteristics are not guaranteed and the EEPROM will be degraded.

Operating the EEPROM above 105°C may result in a degradation of retention characteristics. The fault logging function, which is useful in debugging system problems that may occur at high temperatures, only writes to fault log EEPROM locations. If occasional writes to these registers occur above 105°C , a slight degradation in the data retention characteristics of the fault log may occur.

It is recommended that the EEPROM not be written using STORE_USER_ALL or bulk programming when $T_J > 85^\circ\text{C}$.

The degradation in EEPROM retention for temperatures $>105^\circ\text{C}$ can be approximated by calculating the dimensionless acceleration factor using the following equation.

$$AF = e^{\left[\left(\frac{E_a}{k} \right) \cdot \left(\frac{1}{T_{\text{USE}+273}} - \frac{1}{T_{\text{STRESS}+273}} \right) \right]}$$

where:

AF = acceleration factor

E_a = activation energy = 1.4eV

$k = 8.617 \cdot 10^{-5}$ eV/°K

T_{USE} = 105°C specified junction temperature

T_{STRESS} = actual junction temperature °C

Example: Calculate the effect on retention when operating at a junction temperature of 125°C for 10 hours.

$$T_{\text{STRESS}} = 125^\circ\text{C}$$

$$T_{\text{USE}} = 105^\circ\text{C}$$

$$AF = 8.65$$

Equivalent operating time at $105^\circ\text{C} = 86.5$ hours.

So the overall retention of the EEPROM was degraded by an additional 76.5 hours as a result of operation at a junction temperature of 125°C for 10 hours. Note that the effect of this overstress is negligible when compared to the overall EEPROM retention rating of 175,200 hours at a junction temperature of 105°C .

AUXFAULTB

The MFR_CONFIG2_LTC2972 and MFR_CONFIG3_LTC2972 commands can be used on a per channel basis to select which, if any, fault conditions will cause the AUXFAULTB pin to be driven low. The only fault types which can be propagated to the AUXFAULTB pin are over/under voltage faults.

RESETB

Holding the WDI/RESETB pin low for more than t_{RESETB} will cause the LTC2972 to enter the power-on reset state. While in the power-on reset state, the device will not communicate on the I²C bus. Following the subsequent rising-edge of the WDI/RESETB pin, the LTC2972 will execute its power-on sequence per the user configuration stored in EEPROM. Connect WDI/RESETB to $V_{\text{DD}33}$ with a 10k resistor. WDI/RESETB includes an internal 256µs deglitch filter so additional filter capacitance on this pin is not recommended.

V_{DDIO}

The V_{DDIO} pin defines the input threshold of the SDA, SCL, ALERTB, PWRGD, FAULTB[1:0], CONTROL[1:0], PG[1:0], WDI/RESETB, and WP pins to allow for lower voltage digital communication. An internal resistive divider at the V_{DDIO} pin sets the internal threshold voltage to approximately 45% of the V_{DDIO} pin voltage. The VOUT_EN[1:0], AUX_FAULTB, and SHARE_CLK pins are not affected by the voltage at the V_{DDIO} pin and should always be pulled up to $V_{\text{DD}33}$.

OPERATION

PMBus SERIAL DIGITAL INTERFACE

The LTC2972 communicates with a host (master) using the standard PMBus serial bus interface. The PMBus Timing Diagram shows the timing relationship of the signals on the bus. The two bus lines, SDA and SCL, must be high when the bus is not in use. External pull-up resistors or current sources are required on these lines.

The LTC2972 is a slave device. The master can communicate with the LTC2972 using the following formats:

- Master transmitter, slave receiver
- Master receiver, slave transmitter

The following SMBus commands are supported:

- Write Byte, Write Word, Send Byte
- Read Byte, Read Word, Block Read
- Alert Response Address

Figures 1 to 13 illustrate the aforementioned SMBus protocols. All transactions support PEC (packet error check) and GCP (group command protocol). The Block Read supports 255 bytes of returned data. For this reason, the SMBus timeout may be extended using the `Mfr_config_all_longer_pmbus_timeout` setting.

PMBus

PMBus is an industry standard that defines a means of communication with power conversion devices. It is comprised of an industry standard SMBus serial interface and the PMBus command language.

The PMBus two wire interface is an incremental extension of the SMBus. SMBus is built upon I²C with some minor differences in timing, DC parameters and protocol. The SMBus protocols are more robust than simple I²C byte commands because they provide timeouts to prevent bus hangs and optional Packet Error Checking (PEC) to ensure data integrity. In general, a master device that can be configured for I²C communication can be used for PMBus communication with little or no change to hardware or firmware.

For a description of the minor extensions and exceptions PMBus makes to SMBus, refer to PMBus Specification Part 1 Revision 1.1: Section 5: Transport. This can be found at:

www.pmbus.org

For a description of the differences between SMBus and I²C, refer to System Management Bus (SMBus) Specification Version 2.0: Appendix B – Differences between SMBus and I²C. This can be found at:

www.smbus.org

When using an I²C controller to communicate with a PMBus part it is important that the controller be able to write a byte of data without generating a stop. This will allow the controller to properly form the repeated start of a PMBus read command by concatenating a start command byte write with an I²C read.

Device Address

The I²C/SMBus address of the LTC2972 equals the base address + N where N is a number from 0 to 8. N can be configured by setting the ASEL0 and ASEL1 pins to V_{DD33}, GND or FLOAT. See Table 3. Using one base address and the nine values of N, nine LTC2972s can be connected together to control eighteen outputs. The base address is stored in the MFR_I2C_BASE_ADDRESS register. The base address can be written to any value, but generally should not be changed unless the desired range of addresses overlap existing addresses. Watch that the address range does not overlap with other I²C/SMBus device or global addresses, including I²C/SMBus multiplexers and bus buffers. This will bring you great happiness.

The LTC2972 always responds to its global address and the SMBus Alert Response address regardless of the state of its ASEL pins and the MFR_I2C_BASE_ADDRESS register.

Processing Commands

The LTC2972 uses a dedicated processing block to ensure quick response to all of its commands. There are a few exceptions where the part will NACK a subsequent command because it is still processing the previous command. These are summarized in Table 1 and Table 2. MFR_COMMON is a special command that may always be read even when the part is busy. This provides an alternate method for a host to determine if the LTC2972 is busy.

OPERATION

To assure BUSY faults are not generated in the application the best practice is to add polling after issuing a SEND BYTE, WRITE BYTE or WRITE WORD command. Polling consists of reading the MFR_COMMON command bit 6. Bit 6 is low when the LTC2972 is busy. Monitor bit 6 by reading MFR_COMMON until bit 6 asserts high, then issue the next command. EEPROM commands are in table 1 below and provide typical delays for EEPROM commands most users issue. All EEPROM commands

must be polled due to their long delays. Table 2, Other Commands, documents typical delays for commands that may require more time for the LTC2972 to process. The assumption for these typical delays is the PMBus is running at the maximum specified 400kHz and the commands are issued back-to-back at the minimum delays. If the bus speed is slower or the delays between commands are not the PMBus specified minimums, additional delays may not be required.

Table 1. EEPROM Related Commands

COMMAND	TYPICAL DELAY*	COMMENT
STORE_USER_ALL	$t_{\text{MASS_WRITE}}$	These commands have large delays and require monitoring of MFR_COMMON bit 6. If MFR_COMMON bit 6 is low, the LTC2972 will not accept new commands (except MFR_COMMON) and will be in a busy state. If another command is issued while the device is busy, the address byte will be ACKed, the command byte will be NACKed, and ALERTB will be asserted low. MFR_COMMON may always be read without creating a BUSY fault.
RESTORE_USER_ALL	30ms	
MFR_FAULT_LOG_CLEAR	175ms	
MFR_FAULT_LOG_STORE	20ms	
Internal Fault Log	20ms	
MFR_FAULT_LOG_RESTORE	2ms	
MFR_EE_ERASE	Consult Factory	
MFR_EE_DATA	Consult Factory	

* The typical delay indicates the typical amount of time needed between the stop of the command that enters the busy state and the start of the next command that will not cause a BUSY fault

Table 2. Other Commands

COMMAND	TYPICAL DELAY*	COMMENT
IOUT_CAL_GAIN	<500 μ s	The LTC2972 will not accept new commands (except MFR_COMMON) while it is processing this command and will be in a busy state. If another command is issued while the device is busy, the address byte will be ACKed, the command byte will be NACKed, and ALERTB will be asserted low. MFR_COMMON may always be read without creating a BUSY fault.
MFR_IIN_CAL_GAIN	<500 μ s	
MFR_DATA_PLUS0	<50 μ s	
MFR_DATA_PLUS1	<50 μ s	
MFR_CONFIG	<50 μ s	
TON_RISE	<50 μ s	
VOUT_OV_FAULT_LIMIT	<50 μ s	
VOUT_UV_FAULT_LIMIT	<50 μ s	
MFR_DAC	<50 μ s	

* The typical delay indicates the typical amount of time needed between the stop of the command that enters the busy state and the start of the next command that will not cause a BUSY fault

Other PMBus Timing Notes

COMMAND	COMMENT
CLEAR_FAULTS	The LTC2972 will accept commands while it is completing this command but the affected status flags will not be cleared for up to 500 μ s.

OPERATION

Table 3. LTC2972 Address Look-Up Table with MFR_I2C_BASE_ADDRESS Set to 7-bit 0x5C

ADDRESS PINS		DESCRIPTION	HEX DEVICE ADDRESS		BINARY DEVICE ADDRESS							R/W
ASEL1	ASEL0		7-Bit	8-Bit	6	5	4	3	2	1	0	
X	X	Alert Response	0C	19	0	0	0	1	1	0	0	1
X	X	Global	5B	B6	1	0	1	1	0	1	1	0
L	L	N = 0	5C*	B8	1	0	1	1	1	0	0	0
L	NC	N = 1	5D	BA	1	0	1	1	1	0	1	0
L	H	N = 2	5E	BC	1	0	1	1	1	1	0	0
NC	L	N = 3	5F	BE	1	0	1	1	1	1	1	0
NC	NC	N = 4	60	C0	1	1	0	0	0	0	0	0
NC	H	N = 5	61	C2	1	1	0	0	0	0	1	0
H	L	N = 6	62	C4	1	1	0	0	0	1	0	0
H	NC	N = 7	63	C6	1	1	0	0	0	1	1	0
H	H	N = 8	64	C8	1	1	0	0	1	0	0	0

H = Tie to V_{DD33}, NC = No Connect = Open or Float, L = Tie to GND, X = Don't Care
 *MFR_I2C_BASE_ADDRESS = 7-bit 0x5C (Factory Default)

- S START CONDITION
- Sr REPEATED START CONDITION
- Rd READ (BIT VALUE OF 1)
- Wr WRITE (BIT VALUE OF 0)
- \bar{A} NOT ACKNOWLEDGE (HIGH)
- A ACKNOWLEDGE (LOW)
- P STOP CONDITION
- PEC PACKET ERROR CODE
- MASTER TO SLAVE
- SLAVE TO MASTER
- ... CONTINUATION OF PROTOCOL

2972 F01

Figure 1. PMBus Packet Protocol Diagram Element Key

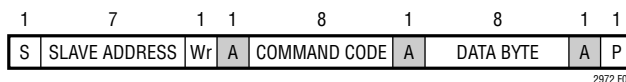

2972 F02

Figure 2. Write Byte Protocol

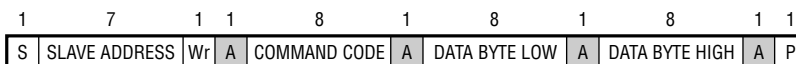

2972 F03

Figure 3. Write Word Protocol

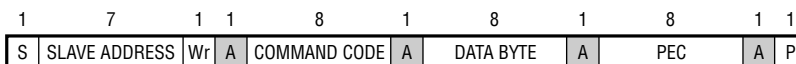

2972 F04

Figure 4. Write Byte Protocol with PEC

OPERATION

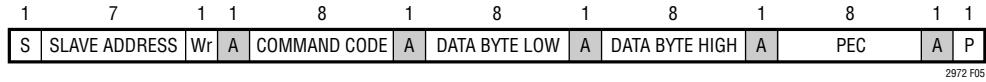

Figure 5. Write Word Protocol with PEC

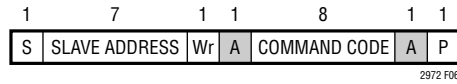

Figure 6. Send Byte Protocol

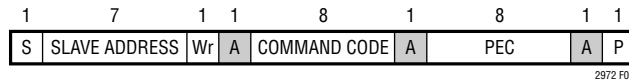

Figure 7. Send Byte Protocol with PEC

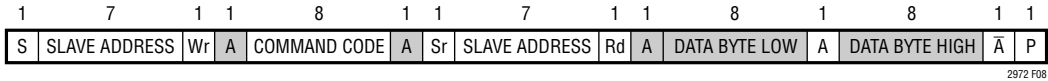

Figure 8. Read Word Protocol

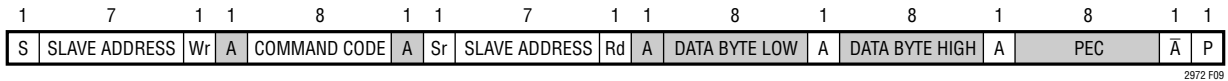

Figure 9. Read Word Protocol with PEC

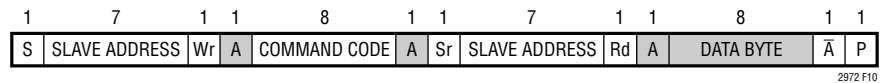

Figure 10. Read Byte Protocol

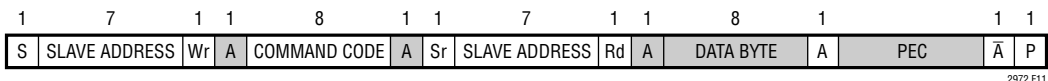

Figure 11. Read Byte Protocol with PEC

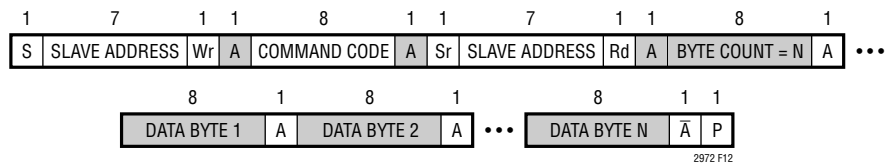

Figure 12. Block Read

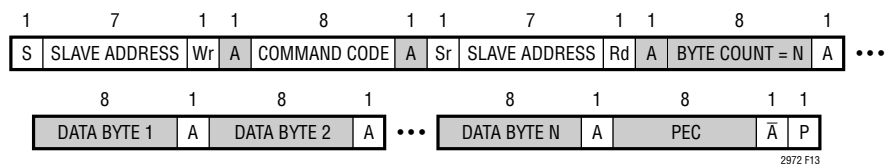

Figure 13. Block Read with PEC

PMBus COMMAND SUMMARY

Summary Table

COMMAND NAME	CMD CODE	DESCRIPTION	TYPE	PAGED	DATA FORMAT	UNITS	EEPROM	DEFAULT VALUE: FLOAT HEX	REF PAGE
PAGE	0x00	Channel or page currently selected for any command that supports paging.	R/W Byte	N	Reg			0x00	31
OPERATION	0x01	Operating mode control. On/Off, Margin High and Margin Low.	R/W Byte	Y	Reg		Y	0x00	37
ON_OFF_CONFIG	0x02	CONTROL pin and PMBus on/off command setting.	R/W Byte	Y	Reg		Y	0x1E	38
CLEAR_FAULTS	0x03	Clear any fault bits that have been set.	Send Byte	Y				NA	68
WRITE_PROTECT	0x10	Level of protection provided by the device against accidental changes.	R/W Byte	N	Reg		Y	0x00	32
STORE_USER_ALL	0x15	Store entire operating memory to EEPROM.	Send Byte	N				NA	46
RESTORE_USER_ALL	0x16	Restore entire operating memory from EEPROM.	Send Byte	N				NA	46
CAPABILITY	0x19	Summary of PMBus optional communication protocols supported by this device.	R Byte	N	Reg			0xB0	88
VOUT_MODE	0x20	Output voltage data format and mantissa exponent (2^{-13}).	R Byte	Y	Reg			0x13	52
VOUT_COMMAND	0x21	Servo target. Nominal DC/DC converter output voltage setpoint.	R/W Word	Y	L16	V	Y	1.0 0x2000	53
VOUT_MAX	0x24	Upper limit on the output voltage the unit can command regardless of any other commands.	R/W Word	Y	L16	V	Y	4.0 0x8000	53
VOUT_MARGIN_HIGH	0x25	Margin high DC/DC converter output voltage setting.	R/W Word	Y	L16	V	Y	1.05 0x219A	53
VOUT_MARGIN_LOW	0x26	Margin low DC/DC converter output voltage setting.	R/W Word	Y	L16	V	Y	0.95 0x1E66	53
VIN_ON	0x35	Input voltage above which power conversion can be enabled.	R/W Word	N	L11	V	Y	10.0 0xD280	49
VIN_OFF	0x36	Input voltage below which power conversion is disabled. Both V _{OUT_EN} pins go off immediately or sequence off after TOFF_DELAY (See Mfr_config_track_enr).	R/W Word	N	L11	V	Y	9.0 0xD240	49
IOUT_CAL_GAIN	0x38	The nominal resistance of the current sense element in mΩ.	R/W Word	Y	L11	mΩ	Y	1.0 0xBA00	54
IOUT_CAL_OFFSET	0x39	Offset applied to the current sense measurement in Amps.	R/W Word	Y	L11	A	Y	0 0x8000	54
VOUT_OV_FAULT_LIMIT	0x40	Output overvoltage fault limit.	R/W Word	Y	L16	V	Y	1.1 0x2333	53
VOUT_OV_FAULT_RESPONSE	0x41	Action to be taken by the device when an output overvoltage fault is detected.	R/W Byte	Y	Reg		Y	0x80	64
VOUT_OV_WARN_LIMIT	0x42	Output overvoltage warning limit.	R/W Word	Y	L16	V	Y	1.075 0x2266	49
VOUT_UV_WARN_LIMIT	0x43	Output undervoltage warning limit.	R/W Word	Y	L16	V	Y	0.925 0x1D9A	49

Note: The data format abbreviations are detailed at the end of this table

PMBus COMMAND SUMMARY

Summary Table

COMMAND NAME	CMD CODE	DESCRIPTION	TYPE	PAGED	DATA FORMAT	UNITS	EEPROM	DEFAULT VALUE: FLOAT HEX	REF PAGE
VOUT_UV_FAULT_LIMIT	0x44	Output undervoltage fault limit. Used for Ton_max_fault and PWRGD pin de-assertion.	R/W Word	Y	L16	V	Y	0.9 0x1CCD	53
VOUT_UV_FAULT_RESPONSE	0x45	Action to be taken by the device when an output undervoltage fault is detected.	R/W Byte	Y	Reg		Y	0x7F	64
IOUT_OC_WARN_LIMIT	0x4A	Output overcurrent warning limit.	R/W Word	Y	L11	A		5.0 0xCA80	54
OT_FAULT_LIMIT	0x4F	Overtemperature fault limit for the external temperature sensor.	R/W Word	Y	L11	°C	Y	65.0 0xEA08	56
OT_FAULT_RESPONSE	0x50	Action to be taken by the device when an overtemperature fault is detected on the external temperature sensor.	R/W Byte	Y	Reg		Y	0xB8	65
OT_WARN_LIMIT	0x51	Overtemperature warning limit for the external temperature sensor.	R/W Word	Y	L11	°C	Y	60.0 0xE3C0	56
UT_WARN_LIMIT	0x52	Undertemperature warning limit for the external temperature sensor.	R/W Word	Y	L11	°C	Y	0 0x8000	56
UT_FAULT_LIMIT	0x53	Undertemperature fault limit for the external temperature sensor.	R/W Word	Y	L11	°C	Y	-5.0 0xCD80	56
UT_FAULT_RESPONSE	0x54	Action to be taken by the device when an undertemperature fault is detected on the external temperature sensor.	R/W Byte	Y	Reg		Y	0xB8	65
VIN_OV_FAULT_LIMIT	0x55	Input overvoltage fault limit measured at VIN_SNS pin.	R/W Word	N	L11	V	Y	15.0 0xD3C0	49
VIN_OV_FAULT_RESPONSE	0x56	Action to be taken by the device when an input overvoltage fault is detected.	R/W Byte	N	Reg		Y	0x80	65
VIN_OV_WARN_LIMIT	0x57	Input overvoltage warning limit measured at VIN_SNS pin.	R/W Word	N	L11	V	Y	14.0 0xD380	49
VIN_UV_WARN_LIMIT	0x58	Input undervoltage warning limit measured at VIN_SNS pin.	R/W Word	N	L11	V	Y	0 0x8000	49
VIN_UV_FAULT_LIMIT	0x59	Input undervoltage fault limit measured at VIN_SNS pin.	R/W Word	N	L11	V	Y	0 0x8000	49
VIN_UV_FAULT_RESPONSE	0x5A	Action to be taken by the device when an input undervoltage fault is detected.	R/W Byte	N	Reg		Y	0x00	65
POWER_GOOD_ON	0x5E	Output voltage at or above which the PWRGD pin should be asserted.	R/W Word	Y	L16	V	Y	0.96 0x1EB8	53
POWER_GOOD_OFF	0x5F	Output voltage at or below which the PWRGD pin should be de-asserted when Mfr_config_all_pwrGD_off_uses_uv is clear.	R/W Word	Y	L16	V	Y	0.94 0x1E14	53
TON_DELAY	0x60	Time from CONTROL pin and/or OPERATION command = ON to V _{OUT_ENn} pin = ON.	R/W Word	Y	L11	ms	Y	1.0 0xBA00	58
TON_RISE	0x61	Time from when the V _{OUT_ENn} pin goes high until the LTC2972 optionally soft-connects its DAC and begins to servo the output voltage to the desired value.	R/W Word	Y	L11	ms	Y	10.0 0xD280	58
TON_MAX_FAULT_LIMIT	0x62	Maximum time from V _{OUT_ENn} = ON assertion that an UV condition will be tolerated before a TON_MAX_FAULT condition results.	R/W Word	Y	L11	ms	Y	15.0 0xD3C0	58

PMBus Command Summary

Summary Table

COMMAND NAME	CMD CODE	DESCRIPTION	TYPE	PAGED	DATA FORMAT	UNITS	EEPROM	DEFAULT VALUE: FLOAT HEX	REF PAGE
TON_MAX_FAULT_RESPONSE	0x63	Action to be taken by the device when a TON_MAX_FAULT event is detected.	R/W Byte	Y	Reg		Y	0xB8	65
TOFF_DELAY	0x64	Time from CONTROL pin and/or OPERATION command = OFF to V _{OUT_ENN} pin = OFF.	R/W Word	Y	L11	ms	Y	1.0 0xBA00	58
STATUS_BYTE	0x78	One byte summary of the unit's fault condition.	R Byte	Y	Reg			NA	69
STATUS_WORD	0x79	Two byte summary of the unit's fault condition.	R Word	Y	Reg			NA	69
STATUS_VOUT	0x7A	Output voltage fault and warning status.	R Byte	Y	Reg			NA	70
STATUS_IOUT	0x7B	Output current fault and warning status.	R Byte	Y	Reg			NA	70
STATUS_INPUT	0x7C	Input supply fault and warning status.	R Byte	N	Reg			NA	70
STATUS_TEMPERATURE	0x7D	External temperature fault and warning status for READ_TEMPERATURE_1.	R Byte	Y	Reg			NA	71
STATUS_CML	0x7E	Communication and memory fault and warning status.	R Byte	N	Reg			NA	71
STATUS_MFR_SPECIFIC	0x80	Manufacturer specific fault and state information.	R Byte	Y	Reg			NA	72
READ_VIN	0x88	Input supply voltage.	R Word	N	L11	V		NA	75
READ_IIN	0x89	DC/DC converter input current.	R Word	N	L11	A		NA	75
READ_VOUT	0x8B	DC/DC converter output voltage.	R Word	Y	L16	V		NA	75
READ_IOUT	0x8C	DC/DC converter output current.	R Word	Y	L11	A		NA	76
READ_TEMPERATURE_1	0x8D	External diode junction temperature. This is the value used for all temperature related processing, including IOUT_CAL_GAIN.	R Word	Y	L11	°C		NA	76
READ_TEMPERATURE_2	0x8E	Internal junction temperature.	R Word	N	L11	°C		NA	76
READ_POUT	0x96	DC/DC converter output power.	R Word	Y	L11	W		NA	77
READ_PIN	0x97	DC/DC converter input power.	R Word	N	L11	W		NA	75
PMBUS_REVISION	0x98	PMBus revision supported by this device. Current revision is 1.1.	R Byte	N	Reg			0x11	88
USER_DATA_00	0xB0	Manufacturer reserved for LTpowerPlay.	R/W Word	N	Reg		Y	NA	89
USER_DATA_01	0xB1	Manufacturer reserved for LTpowerPlay.	R/W Word	Y	Reg		Y	NA	89
USER_DATA_02	0xB2	OEM Reserved.	R/W Word	N	Reg		Y	NA	89
USER_DATA_03	0xB3	Scratchpad location.	R/W Word	Y	Reg		Y	0x0000	89
USER_DATA_04	0xB4	Scratchpad location.	R/W Word	N	Reg		Y	0x0000	89
MFR_FIRST_FAULT	0xB5	First fault information.	R Word	N	Reg			NA	74
MFR_INFO	0xB6	Manufacturer specific information.	R Word	N	Reg			NA	89
MFR_STATUS_2	0xB7	Manufacturer specific status.	R Word	Y	Reg			NA	74
MFR_T_SELF_HEAT	0xB8	Calculated temperature rise due to self-heating of output current sense device above value measured by external temperature sensor.	R Word	Y	L11	°C		NA	56
MFR_IOUT_CAL_GAIN_TAU_INV	0xB9	Inverse of time constant for Mfr_t_self_heat changes scaled by $4 \cdot t_{\text{CONV_SENSE}}$.	R/W Word	Y	L11		Y	0.0 0x8000	56

PMBus COMMAND SUMMARY

Summary Table

COMMAND NAME	CMD CODE	DESCRIPTION	TYPE	PAGED	DATA FORMAT	UNITS	EEPROM	DEFAULT VALUE: FLOAT HEX	REF PAGE
MFR_IOUT_CAL_GAIN_THETA	0xBA	Thermal resistance from inductor core to point measured by external temperature sensor.	R/W Word	Y	L11	°C/W	Y	0.0 0x8000	56
MFR_READ_IOUT	0xBB	Alternate data format for READ_IOUT. One LSB = 2.5mA.	R Word	Y	CF	2.5mA		NA	77
MFR_LTC_RESERVED_2	0xBC	Manufacturer reserved.	R/W Word	Y	Reg			NA	89
MFR_EE_UNLOCK	0xBD	Unlock user EEPROM for access by MFR_EE_ERASE and MFR_EE_DATA commands.	R/W Byte	N	Reg			NA	47
MFR_EE_ERASE	0xBE	Initialize user EEPROM for bulk programming by MFR_EE_DATA.	R/W Byte	N	Reg			NA	47
MFR_EE_DATA	0xBF	Data transferred to and from EEPROM using sequential PMBus word reads or writes. Supports bulk programming.	R/W Word	N	Reg			NA	47
MFR_EIN	0xC0	Input Energy data bytes.	R Block	N	Reg			NA	49
MFR_EIN_CONFIG	0xC1	Configuration register for energy and input current.	R/W Byte	N	Reg		Y	0x00	50
MFR_SPECIAL_LOT	0xC2	Customer dependent codes that identify the factory programmed user configuration stored in EEPROM. Contact factory for default value.	R Byte	Y	Reg		Y	NA	88
MFR_IIN_CAL_GAIN_TC	0xC3	Temperature coefficient applied to IIN_CAL_GAIN.	R/W Word	N	CF	ppm	Y	0x0000	51
MFR_IIN_PEAK	0xC4	Maximum measured value of READ_IIN.	R Word	N	L11	A		NA	76
MFR_IIN_MIN	0xC5	Minimum measured value of READ_IIN.	R Word	N	L11	A		NA	76
MFR_PIN_PEAK	0xC6	Maximum measured value of READ_PIN.	R Word	N	L11	W		NA	76
MFR_PIN_MIN	0xC7	Minimum measured value of READ_PIN.	R Word	N	L11	W		NA	76
MFR_COMMAND_PLUS	0xC8	Alternate access to block read and other data. Commands for all additional hosts.	R/W Word	N	Reg			0x0000	33
MFR_DATA_PLUS0	0xC9	Alternate access to block read and other data. Data for additional host 0.	R/W Word	N	Reg			0x0000	33
MFR_DATA_PLUS1	0xCA	Alternate access to block read and other data. Data for additional host 1.	R/W Word	N	Reg			0x0000	33
MFR_PG_CONFIG	0xCB	PG pin configuration.	R/W Word	Y	Reg		Y	0xC046	60
MFR_CLEAR_ENERGY	0xCC	Clear MFR_EIN time and energy values.	Send Byte	N				NA	51
MFR_DAC_STARTUP	0xCD	DAC output code used at start-up.	R/W Word	Y	Reg		Y	0x0000	53
MFR_PG_GPO	0xCE	PG pin output data register.	R/W Byte	Y	Reg		Y	0x00	62
MFR_CONFIG_LTC2972	0xD0	Configuration bits that are channel specific.	R/W Word	Y	Reg		Y	0x0080	38
MFR_CONFIG_ALL_LTC2972	0xD1	Configuration bits that are common to both pages.	R/W Word	N	Reg		Y	0x007B	44
MFR_FAULTB0_PROPAGATE	0xD2	Configuration that determines if a channel's faulted off state is propagated to the FAULTB0 pin.	R/W Byte	Y	Reg		Y	0x00	67
MFR_FAULTB1_PROPAGATE	0xD3	Configuration that determines if a channel's faulted off state is propagated to the FAULTB1 pin.	R/W Byte	Y	Reg		Y	0x00	67

PMBus COMMAND SUMMARY

Summary Table

COMMAND NAME	CMD CODE	DESCRIPTION	TYPE	PAGED	DATA FORMAT	UNITS	EEPROM	DEFAULT VALUE: FLOAT HEX	REF PAGE
MFR_PWRGD_EN	0xD4	Configuration that maps WDI/RESETB status and individual channel power good to the PWRGD pin.	R/W Word	N	Reg		Y	0x0000	62
MFR_FAULTB0_RESPONSE	0xD5	Action to be taken by the device when the FAULTB0 pin is asserted low.	R/W Byte	N	Reg		Y	0x00	67
MFR_FAULTB1_RESPONSE	0xD6	Action to be taken by the device when the FAULTB1 pin is asserted low.	R/W Byte	N	Reg		Y	0x00	67
MFR_IOUT_PEAK	0xD7	Maximum measured value of READ_IOUT.	R Word	Y	L11	A		NA	78
MFR_IOUT_MIN	0xD8	Minimum measured value of READ_IOUT.	R Word	Y	L11	A		NA	79
MFR_CONFIG2_LTC2972	0xD9	Configuration bits that are channel specific.	R/W Byte	N	Reg		Y	0x00	41
MFR_CONFIG3_LTC2972	0xDA	Configuration bits that are channel specific.	R/W Byte	N	Reg		Y	0x00	41
MFR_RETRY_DELAY	0xDB	Retry interval during FAULT retry mode.	R/W Word	N	L11	ms	Y	200 0xF320	66
MFR_RESTART_DELAY	0xDC	Delay from actual CONTROL active edge to virtual CONTROL active edge.	R/W Word	N	L11	ms	Y	400 0xFB20	59
MFR_VOUT_PEAK	0xDD	Maximum measured value of READ_VOUT.	R Word	Y	L16	V		NA	78
MFR_VIN_PEAK	0xDE	Maximum measured value of READ_VIN.	R Word	N	L11	V		NA	78
MFR_TEMPERATURE_1_PEAK	0xDF	Maximum measured value of READ_TEMPERATURE_1.	R Word	Y	L11	°C		NA	78
MFR_DAC	0xE0	The code of the 10-bit DAC.	R/W Word	Y	Reg			NA	53
MFR_POWERGOOD_ASSERTION_DELAY	0xE1	PWRGD pin output assertion delay.	R/W Word	N	L11	ms	Y	100 0xEB20	62
MFR_WATCHDOG_T_FIRST	0xE2	First watchdog timer interval.	R/W Word	N	L11	ms	Y	0 0x8000	63
MFR_WATCHDOG_T	0xE3	Watchdog timer interval.	R/W Word	N	L11	ms	Y	0 0x8000	63
MFR_PAGE_FF_MASK	0xE4	Configuration defining which channels respond to global page commands (PAGE=0xFF).	R/W Byte	N	Reg		Y	0x03	33
MFR_PADS	0xE5	Current state of selected digital I/O pads.	R Word	N	Reg			NA	72
MFR_I2C_BASE_ADDRESS	0xE6	Base value of the I ² C/SMBus address byte.	R/W Byte	N	Reg		Y	0x5C	33
MFR_SPECIAL_ID	0xE7	Manufacturer code for identifying the LTC2972.	R Word	N	Reg		Y	784 0x0310	88
MFR_IIN_CAL_GAIN	0xE8	The nominal resistance of the input current sense element in mΩ.	R/W Word	N	L11	mΩ	Y	1.0 0xBA00	51
MFR_VOUT_DISCHARGE_THRESHOLD	0xE9	Coefficient used to multiply VOUT_COMMAND in order to determine V _{OUT} off threshold voltage.	R/W Word	Y	L11		Y	2.0 0xC200	53
MFR_FAULT_LOG_STORE	0xEA	Command a transfer of the fault log from RAM to EEPROM.	Send Byte	N				NA	80
MFR_FAULT_LOG_RESTORE	0xEB	Command a transfer of the fault log previously stored in EEPROM back to RAM.	Send Byte	N				NA	80
MFR_FAULT_LOG_CLEAR	0xEC	Initialize the EEPROM block reserved for fault logging and clear any previous fault logging locks.	Send Byte	N				NA	80

PMBus COMMAND SUMMARY

Summary Table

COMMAND NAME	CMD CODE	DESCRIPTION	TYPE	PAGED	DATA FORMAT	UNITS	EEPROM	DEFAULT VALUE: FLOAT HEX	REF PAGE
MFR_FAULT_LOG_STATUS	0xED	Fault logging status.	R Byte	N	Reg		Y	NA	80
MFR_FAULT_LOG	0xEE	Fault log data bytes. This sequentially retrieved data is used to assemble a complete fault log.	R Block	N	Reg		Y	NA	80
MFR_COMMON	0xEF	Manufacturer status bits that are common across multiple ADI chips.	R Byte	N	Reg			NA	73
MFR_IOUT_CAL_GAIN_TC	0xF6	Temperature coefficient applied to IOUT_CAL_GAIN.	R/W Word	Y	CF	ppm	Y	0x0000	54
MFR_RETRY_COUNT	0xF7	Retry count for all faulted off conditions that enable retry.	R/W Byte	N	Reg		Y	0x07	66
MFR_TEMP_1_GAIN	0xF8	Inverse of external diode temperature non ideality factor. One LSB = 2^{-14} .	R/W Word	Y	CF		Y	1 0x4000	56
MFR_TEMP_1_OFFSET	0xF9	Offset value for the external temperature.	R/W Word	Y	L11	°C	Y	0 0x8000	56
MFR_IOUT_SENSE_VOLTAGE	0xFA	Absolute value of the voltage between I_{SENSEn} and I_{SENSEm} . One LSB = 3.05µV or 91.5µV.	R Word	Y	CF	3.05µV		NA	78
MFR_VOUT_MIN	0xFB	Minimum measured value of READ_VOUT.	R Word	Y	L16	V		NA	78
MFR_VIN_MIN	0xFC	Minimum measured value of READ_VIN.	R Word	N	L11	V		NA	78
MFR_TEMPERATURE_1_MIN	0xFD	Minimum measured value of READ_TEMPERATURE_1.	R Word	Y	L11	°C		NA	79

Data Formats

L11	Linear_5s_11s	<p>PMBus data field b[15:0]. Value = $Y \cdot 2^N$ where $N = b[15:11]$ is a 5-bit two's complement integer and $Y = b[10:0]$ is an 11-bit two's complement integer. Example: READ_VIN = 10V For b[15:0] = 0xD280 = 1101_0010_1000_0000b Value = $640 \cdot 2^{-6} = 10$ See PMBus Rev 1.1 Spec Part II: Paragraph 7.1.</p>
L16	Linear_16u	<p>PMBus data field b[15:0]. Value = $Y \cdot 2^N$ where $Y = b[15:0]$ is an unsigned integer and $N = \text{Vout_mode_parameter}$ is a 5-bit two's complement exponent that is hardwired to -13 decimal. Example: VOUT_COMMAND = 4.75V For b[15:0] = 0x9800 = 1001_1000_0000_0000b Value = $38912 \cdot 2^{-13} = 4.75$ See PMBus Rev 1.1 Spec Part II: Paragraph 8.3.1.</p>
Reg	Register	<p>PMBus data field b[15:0] or b[7:0]. Bit field meaning is defined in detailed PMBus Command Register Description.</p>
CF	Custom Format	<p>PMBus data field b[15:0]. Value is defined in detailed PMBus Command Register Description. This is often an unsigned or two's complement integer scaled by an MFR specific constant.</p>

PMBus COMMAND DESCRIPTION

ADDRESSING AND WRITE PROTECT

COMMAND NAME	CMD CODE	DESCRIPTION	TYPE	PAGED	FORMAT	UNITS	EEPROM	DEFAULT VALUE	REF PAGE
PAGE	0x00	Channel or page currently selected for any command that supports paging.	R/W Byte	N	Reg			0x00	31
WRITE_PROTECT	0x10	Level of protection provided by the device against accidental changes.	R/W Byte	N	Reg		Y	0x00	32
MFR_I2C_BASE_ADDRESS	0xE6	Base value of the I ² C/SMBus address byte.	R/W Byte	N	Reg		Y	0x5C	33
MFR_PAGE_FF_MASK	0xE4	Configuration defining which channels respond to global page commands (PAGE=0xFF).	R/W Byte	N	Reg		Y	0x03	33
MFR_COMMAND_PLUS	0xC8	Alternate access to block read and other data. Commands for all additional hosts.	R/W Word	N	Reg				33
MFR_DATA_PLUS0	0xC9	Alternate access to block read and other data. Data for additional host 0.	R/W Word	N	Reg				33
MFR_DATA_PLUS1	0xCA	Alternate access to block read and other data. Data for additional host 1.	R/W Word	N	Reg				33

PAGE

The LTC2972 has two pages that correspond to the two DC/DC converter channels that can be managed. Each DC/DC converter channel can be uniquely programmed by first setting the appropriate page.

Setting PAGE = 0xFF allows a simultaneous write to both pages for PMBus commands that support global page programming. The only commands that support PAGE = 0xFF are CLEAR_FAULTS, OPERATION and ON_OFF_CONFIG. See MFR_PAGE_FF_MASK for additional options. Reading any paged PMBus register with PAGE = 0xFF returns unpredictable data and will trigger a CML fault. Writes to paged commands that do not support PAGE = 0xFF with PAGE = 0xFF will be ignored and generate a CML fault.

PAGE Data Contents

BIT(S)	SYMBOL	OPERATION
b[7:0]	Page	Page operation. 0x00: All PMBus commands address channel/page 0. 0x01: All PMBus commands address channel/page 1. 0xXX: All non specified values reserved. 0xFF: A single PMBus write/send to commands that support this mode will simultaneously address all channel/pages with MFR_PAGE_FF_MASK enabled.

PMBus COMMAND DESCRIPTION

WRITE_PROTECT

The WRITE_PROTECT command provides protection against accidental programming of the LTC2972 command registers. All supported commands may have their parameters read, regardless of the WRITE_PROTECT setting, and the EEPROM contents can also be read regardless of the WRITE_PROTECT settings.

There are two levels of protection:

- Level 1: Nothing can be changed except the level of write protection itself. Values can be read from both pages. This setting can be stored to EEPROM.
- Level 2: Nothing can be changed except for the level of protection, channel on/off state, clearing of faults and energy, and PG pin general-purpose output force states. Values can be read from both pages. This setting can be stored to EEPROM.

WRITE_PROTECT Data Contents

BIT(S)	SYMBOL	OPERATION
b[7:0]	Write_protect[7:0]	1000_0000b: Level 1 Protection – Disable all writes except to the WRITE_PROTECT, PAGE, MFR_EE_UNLOCK, STORE_USER_ALL and MFR_COMMAND_PLUS commands. 0100_0000b: Level 2 Protection – Disable all writes except to the WRITE_PROTECT, PAGE, MFR_EE_UNLOCK, STORE_USER_ALL, OPERATION, MFR_COMMAND_PLUS, MFR_PAGE_FF_MASK, MFR_CLEAR_ENERGY, MFR_PG_GPO, and CLEAR_FAULTS commands. 0000_0000b: Enable writes to all commands. xxxx_xxxx b: All other values reserved.

WRITE PROTECT Pin

The WP pin allows the user to write-protect the LTC2972's configuration registers. The WP pin is active high, and when asserted it provides Level 2 protection: all writes are disabled except to the WRITE_PROTECT, PAGE, MFR_EE_UNLOCK, STORE_USER_ALL, OPERATION, MFR_COMMAND_PLUS, MFR_PAGE_FF_MASK, CLEAR_FAULTS, MFR_PG_GPO, and MFR_CLEAR_ENERGY commands. The most restrictive setting between the WP pin and WRITE_PROTECT command will override. For example if WP = 1 and WRITE_PROTECT = 0x80, then the WRITE_PROTECT command overrides, since it is the most restrictive.

WP Pin State	WRITE_PROTECT Command Value	Write Protect Level
Low	0x00	No write protection
	0x40	Level 2
	0x80	Level 1
High	0x00	Level 2
	0x40	Level 2
	0x80	Level 1

PMBus COMMAND DESCRIPTION

MFR_PAGE_FF_MASK

The MFR_PAGE_FF_MASK command is used to select which channels respond when the global page command (PAGE = 0xFF) is in use.

MFR_PAGE_FF_MASK Data Contents

BIT(S)	SYMBOL	OPERATION
b[7:2]	Reserved	Always returns 0000b
b[1]	Mfr_page_ff_mask_chan1	Channel 1 masking of global page command (PAGE=0xFF) accesses 0 = ignore global page command accesses 1 = fully respond to global page command accesses
b[0]	Mfr_page_ff_mask_chan0	Channel 0 masking of global page command (PAGE = 0xFF) accesses 0 = ignore global page command accesses 1 = fully respond to global page command accesses

MFR_I2C_BASE_ADDRESS

The MFR_I2C_BASE_ADDRESS command determines the base value for the I²C/SMBus address byte. Offsets of 0 to 8 are added to this base address to generate the device I²C/SMBus address. The part responds to the device address. For example, with the factory default MFR_I2C_BASE_ADDRESS of 0x5C, with both ASEL1 and ASELO High (Offset N = 8), the device address would be 0x5C + 8 = 0x64.

MFR_I2C_BASE_ADDRESS Data Contents

BIT(S)	SYMBOL	OPERATION
b[7]	Reserved	Read only, always returns 0.
b[6:0]	I2c_base_address	This 7-bit value determines the base value of the 7-bit I ² C/SMBus address. See Device Address in the Operation section.

MFR_COMMAND_PLUS

MFR_DATA_PLUS0 and MFR_DATA_PLUS1

MFR_STATUS_PLUS0, and MFR_STATUS_PLUS1

Similar to the PAGE register, these registers allow the user to indirectly address memory. These registers are useful to advanced users for reading or writing memory as described below.

Command Plus operations use a sequence of word commands to support the following:

- An alternate method for reading block data using sequential standard word reads.
- A peek operation that allows up to two additional hosts to read an internal register using PMBus word protocol where each host has a unique page.
- A poke operation that allows up to two additional hosts to write an internal register using PMBus word protocol where each host has a unique page.
- Peek, Poke and Command Plus block reads do not interfere with normal PMBus accesses or page values set by PAGE. This enables multi master support for up to 3 hosts.

PMBus COMMAND DESCRIPTION

MFR_COMMAND_PLUS Data Contents

BIT(S)	SYMBOL	OPERATION
b[15]	Mfr_command_plus_reserved	Reserved. Always returns 0.
b[14]	Mfr_command_plus_id	Command plus host ID 0: Mfr_command_plus pointer and page are cached and used for all Mfr_data_plus0 accesses. 1: Mfr_command_plus pointer and page are cached and used for all Mfr_data_plus1 accesses.
b[13:9]	Mfr_command_plus_page	Page to be used when peeking or poking via Mfr_data_plus0 or Mfr_data_plus1. Allowed values are 0 through 3. This page value is cached separately for Mfr_data_plus0 and Mfr_data_plus1 based on the value of Mfr_command_plus_id when this register is written.
b[8:0]	Mfr_command_plus_pointer	Internal memory location accessed by Mfr_data_plus0 or Mfr_data_plus1. Mfr_data_plus0 and Mfr_data_plus1 pointers are cached separately. Legal values are listed in the CMD Code column of the PMBus COMMAND SUMMARY table. All other values are reserved, except for the special poke enable/disable values listed in the Enabling And Disabling Poke Operations section, and the command values listed below for Mfr_status_plus0 and Mfr_status_plus1.

MFR_DATA_PLUS0 and MFR_DATA_PLUS1 Data Contents

BIT(S)	SYMBOL	OPERATION
b[15:0]	Mfr_data_plus0 Mfr_data_plus1	A read from this register returns data referenced by the last matching Mfr_command_plus write. More specifically, writes to Mfr_command_plus by host 0 update Mfr_data_plus0, and writes to Mfr_command_plus by host1 update Mfr_data_plus1. Multiple sequential reads while pointer = Mfr_fault_Log return the complete contents of the block read buffer. Block reads beyond the end of buffer return zeros. A write to this register will transfer the data to the location referenced by the last matching Mfr_command_plus_pointer when the Poke operation protocol described in the Poke Operation Using Mfr_data_plus0 section is followed.

MFR_STATUS_PLUS0 and MFR_STATUS_PLUS1 Data Contents

BIT(S)	SYMBOL	OPERATION
b[7:2]	Reserved	
b[1]	Mfr_status_plus_poke_failed0 Mfr_status_plus_poke_failed1	Status of most recent poke for matching host. 0: Last poke operation did not fail. 1: Last poke operation failed because pokes were not enabled as described in Enabling and Disabling Poke Operations section.
b[0]	Mfr_status_plus_block_peek_failed0 Mfr_status_plus_block_peek_failed1	Status of most recent block peek for matching host. 0: Last block peek was not aborted. 1: Last block peek was aborted due to an intervening fault log EEPROM write, MFR_FAULT_LOG_STORE command, or standard PMBus block read of MFR_FAULT_LOG. The intervening operation is always completed cleanly.

MFR_STATUS_PLUS0 is at command location 0x2C, and MFR_STATUS_PLUS1 is at command location 0x2D. These correspond to reserved PMBus command locations. These two status registers can only be read via Command Plus peeks.

Reading Fault Log Using Command Plus and MFR_DATA_PLUS0

Write Mfr_command_plus_pointer = 0xEE with Mfr_command_plus_page = 0 and Mfr_command_plus_id = 0.

Read data from Mfr_data_plus0; each read returns the next data word of the MFR_FAULT_LOG command:

- The first word read is Byte_count[15:0] = 0x00FF.

PMBus COMMAND DESCRIPTION

- The next set of words read is the Preamble with 2 bytes packed into a word. Refer to the Fault Log section for details.
- The next set of words read is the Cyclical Loop Data with 2 bytes per word. Refer to the Fault Log section for details.
- Extra reads return zero.
- Interleaved PMBus word and byte commands do not interfere with an ongoing Command Plus block read.
- Interleaved PMBus block reads of MFR_FAULT_LOG will interrupt this command.

Check status to be sure the data just read was all valid:

- Write `Mfr_command_plus_pointer = 0x2C` with `Mfr_command_plus_page = 0` and `Mfr_command_plus_id = 0`.
- Read data from `Mfr_data_plus0` and confirm that `Mfr_status_plus_block_peek_failed0 = 0`.

Reading Energy Using MFR_COMMAND_PLUS and MFR_DATA_PLUS0

Write `Mfr_command_plus_pointer = 0xC0` with `Mfr_command_plus_page = 0` and `Mfr_command_plus_id = 0`.

Read data from `Mfr_data_plus_0`; each read returns the next data word of the MFR_EIN command:

- `Byte_count[15:0] = 0x000C`
- `Energy_value[15:0]`
- `Energy_value[31:16]`
- `Energy_value[47:32]`
- `Energy_time[15:0]`
- `Energy_time[31:16]`
- `Energy_time[47:32]`

Peek Operation Using MFR_DATA_PLUS0

Internal words and bytes may be read using Command Plus:

Write `Mfr_command_plus_pointer = CMD_CODE` with `Mfr_command_plus_page = page` and `Mfr_command_plus_id = 0`.

The `CMD_CODE`'s are listed in the PMBus COMMAND SUMMARY table.

Read data from `Mfr_data_plus0`. Data is always read using a word read. Byte data is returned with upper byte set to 0.

Enabling and Disabling Poke Operations

Poke operations to `Mfr_data_plus0` are enabled by writing `Mfr_command_plus = 0x0BF6`.

Poke operations to `Mfr_data_plus0` are disabled by writing `Mfr_command_plus = 0x01F6`.

Poke operations to `Mfr_data_plus1` are enabled by writing `Mfr_command_plus = 0x4BF6`.

Poke operations to `Mfr_data_plus1` are disabled by writing `Mfr_command_plus = 0x41F6`.

PMBus COMMAND DESCRIPTION

Poke Operation Using Mfr_data_plus0

Internal words and bytes may be written using Command Plus:

Enable poke access for Mfr_data_plus0. This need only be done once after a power-up or WDI reset.

Write Mfr_command_plus_pointer = CMD_CODE with Mfr_command_plus_page = page and Mfr_command_plus_id = 0.

The CMD_CODEs are listed in the PMBus COMMAND SUMMARY table.

Write the new data value to MFR_DATA_PLUS0

Optionally check status to be sure data was written as desired:

- Write Mfr_command_plus_pointer = 0x2C with Mfr_command_plus_page = 0 and Mfr_command_plus_id = 0.
- Read data from Mfr_data_plus0 and confirm that Mfr_status_plus_poke_failed0 = 0.

Command Plus Operations Using MFR_DATA_PLUS1

All the previous operations may be accessed via Mfr_data_plus1 by substituting Mfr_command_plus_id value with a 1. Poke operations must be enabled for Mfr_data_plus1.

ON/OFF CONTROL, MARGINING AND CONFIGURATION

COMMAND NAME	CMD CODE	DESCRIPTION	TYPE	PAGED	FORMAT	UNITS	EEPROM	DEFAULT VALUE	REF PAGE
OPERATION	0x01	Operating mode control. On/Off, Margin High and Margin Low.	R/W Byte	Y	Reg		Y	0x00	37
ON_OFF_CONFIG	0x02	CONTROL pin and PMBus on/off command setting.	R/W Byte	Y	Reg		Y	0x12	38
MFR_CONFIG_LTC2972	0xD0	Configuration bits that are channel specific.	R/W Word	Y	Reg		Y	0x0080	38
MFR_CONFIG2_LTC2972	0xD9	Configuration bits that are channel specific.	R/W Byte	N	Reg		Y	0x00	41
MFR_CONFIG3_LTC2972	0xDA	Configuration bits that are channel specific.	R/W Byte	N	Reg		Y	0x00	41
MFR_CONFIG_ALL_LTC2972	0xD1	Configuration bits that are common to both pages.	R/W Word	N	Reg		Y	0x007B	44

PMBus COMMAND DESCRIPTION

OPERATION

The OPERATION command is used to turn the unit on and off in conjunction with the CONTROL pin and ON_OFF_CONFIG. This command register responds to the global page command (PAGE = 0xFF). The contents and functions of the data byte are shown in the following tables. A minimum t_{OFF_MIN} wait time must be observed between any OPERATION commands used to turn the unit off and then back on.

OPERATION Data Contents (On_off_config_use_pmbus = 1)

SYMBOL	Action	Operation_control[1:0]	Operation_margin[1:0]	Operation_fault[1:0]	Reserved (Read Only)
BITS		b[7:6]	b[5:4]	b[3:2]	b[1:0]
FUNCTION	Turn off immediately	00	XX	XX	00
	Sequence on	10	00	XX	00
	Margin low (ignore faults and warnings)	10	01	01	00
	Margin low	10	01	10	00
	Margin high (ignore faults and warnings)	10	10	01	00
	Margin high	10	10	10	00
	Sequence off with margin to nominal	01	00	XX	00
	Sequence off with margin low (ignore faults and warnings)	01	01	01	00
	Sequence off with margin low	01	01	10	00
	Sequence off with margin high (ignore faults and warnings)	01	10	01	00
	Sequence off with margin high	01	10	10	00
	Reserved	All remaining combinations			

OPERATION Data Contents (On_off_config_use_pmbus = 0)

On or Off

SYMBOL	Action	Operation_control[1:0]	Operation_margin[1:0]	Operation_fault[1:0]	Reserved (Read Only)
BITS		b[7:6]	b[5:4]	b[3:2]	b[1:0]
FUNCTION	Output at nominal	00, 01 or 10	00	XX	00
	Margin low (ignore faults and warnings)	00, 01 or 10	01	01	00
	Margin low	00, 01 or 10	01	10	00
	Margin high (ignore faults and warnings)	00, 01 or 10	10	01	00
	Margin high	00, 01 or 10	10	10	00
	Reserved	All remaining combinations			

PMBus COMMAND DESCRIPTION

ON_OFF_CONFIG

The ON_OFF_CONFIG command configures the combination of CONTROL pin input and PMBus commands needed to turn the LTC2972 on/off, including the power-on behavior, as shown in the following table. This command register responds to the global page command (PAGE = 0xFF). After the part has initialized, an additional comparator monitors VIN_SNS. The VIN_ON threshold must be exceeded before the output power sequencing can begin. After V_{IN} is initially applied, the part will typically require t_{INIT} to initialize and begin the TON_DELAY timer. The readback of voltages and currents may require an additional wait for t_{UPDATE_ADC}. A minimum t_{OFF_MIN} wait time must be observed for any CONTROL pin used toggle to turn the unit off and then back on.

ON_OFF_CONFIG Data Contents

BIT(S)	SYMBOL	OPERATION
b[7:5]	Reserved	Don't care. Always returns 0.
b[4]	On_off_config_controlled_on	Control default autonomous power up operation. 0: Unit powers up regardless of the CONTROL pin or OPERATION value. Unit always powers up with sequencing. To turn unit on without sequencing, set TON_DELAY = 0. 1: Unit does not power up unless commanded by the CONTROL pin and/or the OPERATION command on the serial bus. If On_off_config[3:2] = 00, the unit never powers up.
b[3]	On_off_config_use_pmbus	Controls how the unit responds to commands received via the serial bus. 0: Unit ignores the Operation_control[1:0]. 1: Unit responds to Operation_control[1:0]. Depending on On_off_config_use_control, the unit may also require the CONTROL pin to be asserted for the unit to start.
b[2]	On_off_config_use_control	Controls how unit responds to the CONTROL pin. 0: Unit ignores the CONTROL pin. 1: Unit requires the CONTROL pin to be asserted to start the unit. Depending on On_off_config_use_pmbus the OPERATION command may also be required to instruct the device to start.
b[1]	Reserved	Not supported. Always returns 1.
b[0]	On_off_config_control_fast_off	CONTROL pin turn off action when commanding the unit to turn off. 0: Use the programmed TOFF_DELAY. 1: Turn off the output and stop transferring energy as quickly as possible. The device does not sink current in order to decrease the output voltage fall time.

MFR_CONFIG_LTC2972

This command is used to configure various manufacturer specific operating parameters for each channel.

PMBus COMMAND DESCRIPTION

MFR_CONFIG_LTC2972 Data Contents

BIT(S)	SYMBOL	OPERATION
b[15]	Mfr_config_track_en	Select if channel is a slave in a tracked power supply system. 0: Channel is not a slave in a tracked power supply system. 1: Channel is a slave in a tracked power supply system. Setting this bit disables UV detection during TOFF_DELAY.
b[14]	Mfr_config_cascade_on	Configures channel's control pin for cascade sequence ON. There is no provision for cascade sequence OFF. See description for time based sequence OFF options.
b[13:12]	Mfr_config_controln_sel	Selects the active control pin input (CONTROL0, CONTROL1) for this channel. 00: Select CONTROL0 pin. 01: Select CONTROL1 pin. 10: Reserved. 11: Reserved.
b[11]	Mfr_config_fast_servo_off	Disables fast servo when margining or trimming output voltages: 0: fast-servo enabled. 1: fast-servo disabled.
b[10]	Mfr_config_supervisor_resolution	Selects voltage supervisor resolution: 0: high resolution = 4mV/LSB, range for $V_{VSENSEPN} - V_{VSENSEMn}$ is 0 to 3.8V 1: low resolution = 8mV/LSB, range for $V_{VSENSEPN} - V_{VSENSEMn}$ is 0 to 6.0V
b[9]	Reserved	Always returns 0.
b[8]	Mfr_config_imon_sel	Select input range of Current Sense Channel: 0: DCR Sense telemetry mode, Range for $V_{ISENSEPN} - V_{ISENSEMN}$ is -170mV to +170mV 1: Buffered IMON telemetry mode, Range for $V_{ISENSEPN} - V_{ISENSEMN}$ is -0.1V to 6.0V
b[7]	Mfr_config_servo_continuous	Select whether the UNIT should continuously servo V_{OUT} after it has reached a new margin or nominal target. Only applies when Mfr_config_dac_mode = 00b. 0: Do not continuously servo V_{OUT} after reaching initial target. 1: Continuously servo V_{OUT} to target.
b[6]	Mfr_config_servo_on_warn	Control re-servo on warning feature. Only applies when Mfr_config_dac_mode = 00b and Mfr_config_servo_continuous = 0. 0: Do not allow the unit to re-servo when a V_{OUT} warning threshold is met or exceeded. 1: Allow the unit to re-servo V_{OUT} to nominal target if $V_{OUT} \geq V(V_{out_ov_warn_limit})$ or $V_{OUT} \leq V(V_{out_uv_warn_limit})$.
b[5:4]	Mfr_config_dac_mode	Determines how DAC is used when channel is in the ON state and TON_RISE has elapsed. 00: Soft-connect (if needed) and servo to target. 01: DAC not connected. 10: DAC connected immediately using value from MFR_DAC command. If this is the configuration after a reset or RESTORE_USER_ALL, The value in MFR_DAC_STARTUP will be used to set the DAC output. 11: DAC is soft-connected. After soft-connect is complete MFR_DAC may be written.
b[3]	Reserved	Always set to 1.
b[2]	Mfr_config_vo_en_wpd_en	VOUT_EN current-limited pull-down enable. 0: Use a fast N-channel device to pull down VOUT_EN pin when the channel is off for any reason. 1: Use weak current-limited pull-down to discharge VOUT_EN pin when channel is off due to soft stop by the CONTROL pin and/or OPERATION command. If the channel is off due to a fault, use the fast pull-down on the VOUT_EN pin.

PMBus COMMAND DESCRIPTION

MFR_CONFIG_LTC2972 Data Contents

BIT(S)	SYMBOL	OPERATION
b[1]	Mfr_config_dac_gain	DAC buffer gain. 0: Select DAC buffer gain dac_gain_0 (1.38V full-scale). 1: Select DAC buffer gain dac_gain_1 (2.65V full-scale).
b[0]	Mfr_config_dac_pol	DAC output polarity. 0: Encodes negative (inverting) DC/DC converter trim input. 1: Encodes positive (non-inverting) DC/DC converter trim input.

Cascade Sequence ON with Time-Based Sequence OFF

Cascade sequence ON allows a master power supply to sequence on a series of slave supplies by connecting each power supply's power good output, or the LTC2972's configured PG pin, to the control pin of the next power supply, or LTC2972 channel, in the chain. Please note that the LTC2972's PWRGD pin should not be used for cascade sequencing. Power good based cascade sequence OFF is not supported, OFF sequencing must be managed using immediate or time based sequence OFF. See also Tracking Based Sequencing section.

Cascade sequence ON is illustrated in Figure 14. For each slave channel Mfr_config_cascade_on is asserted high and the associated control input is connected to the power good output of the previous power supply. In this configuration each slave channel's startup is delayed until the previous supply has powered up.

Cascade sequence OFF is not directly supported. Options for reversing the sequence when turning the supplies off include:

- Using the OPERATION command to turn off all the channels with an appropriate off delay.
- Using the FAULT pin to bring all the channels down immediately or in sequence with an appropriate off delay.

When asserted, Mfr_config_cascade_on enables a slave channel to honor fault retries even when its control pin is low. Additionally, if the system has faulted off after zero or a finite number of retries, an OPERATION command may be used to turn all cascade channels off then on to clear the faulted off state when the slave's control pin is low. For this reason we refer to the control pin as being redefined as a sequence pin.

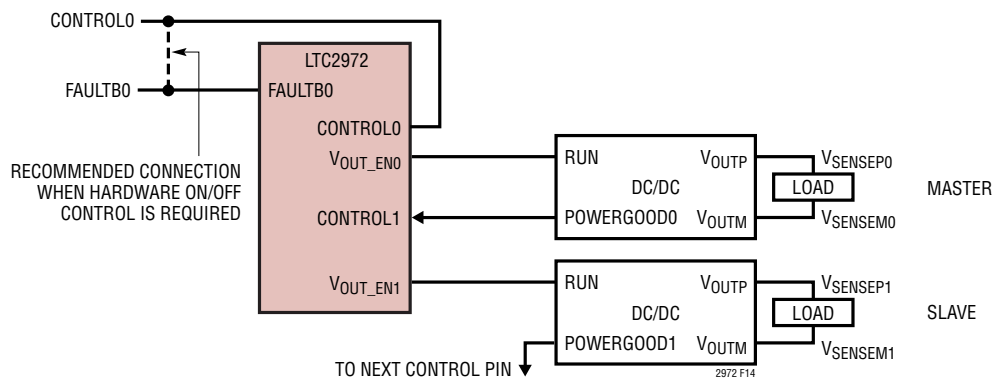

Figure 14. LTC2972 Configured to Cascade Sequence ON and Time-Base Sequence OFF

PMBus COMMAND DESCRIPTION

The waveform of Figure 15 illustrates cascade sequence ON and time based sequence OFF using the configuration illustrated in Figure 14. In this example the FAULTB0 pin is used as a broadcast off signal. Turning the system off with the FAULTB0 requires all slave channels to be configured with `Mfr_faultb0_response_chann` asserted high. After the system is turned off, the LTC2972 will assert ALERTB with all slave channels indicating a `Status_mfr_fault0_in` event.

MFR_CONFIG2_LTC2972

This command register determines whether V_{OUT} overvoltage faults from a given channel cause the AUXFAULTB pin to be pulled low.

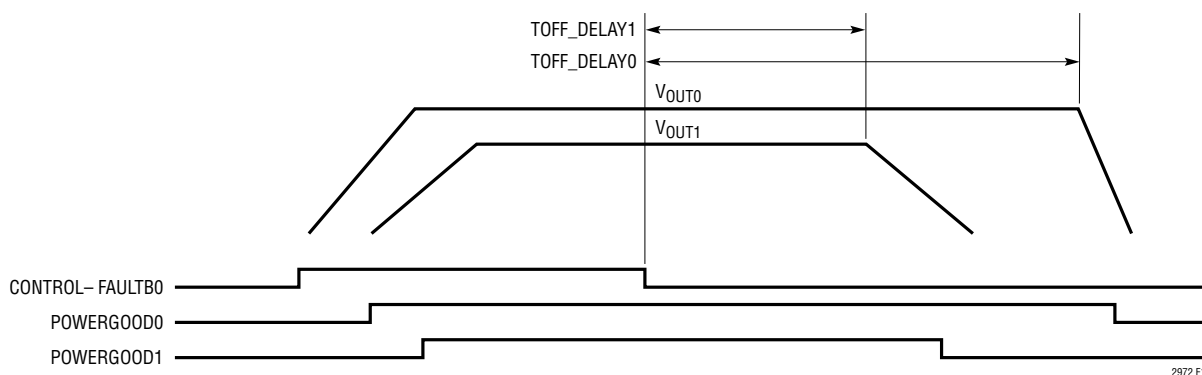

Figure 15. Cascade Sequence ON with Time Based Sequence Down on FAULT0

MFR_CONFIG2_LTC2972 Data Contents

BIT(S)	SYMBOL	OPERATION
b[1]	<code>Mfr_auxfaultb_ov_fault_response_chan1</code>	Response to channel 1 $V_{OUT_OV_FAULT}$. 1 = Pull AUXFAULTB low via fast pull-down. 0 = Do not pull AUXFAULTB low.
b[0]	<code>Mfr_auxfaultb_ov_fault_response_chan0</code>	Response to channel 0 $V_{OUT_OV_FAULT}$. 1 = Pull AUXFAULTB low via fast pull-down. 0 = Do not pull AUXFAULTB low.

MFR_CONFIG3_LTC2972

This command register determines whether V_{OUT} undervoltage faults from a given channel cause the AUXFAULTB pin to be pulled low.

MFR_CONFIG3_LTC2972 Data Contents

BIT(S)	SYMBOL	OPERATION
b[1]	<code>Mfr_auxfaultb_uv_fault_response_chan1</code>	Response to channel 1 $V_{OUT_UV_FAULT}$. 1 = Pull AUXFAULTB low via fast pull-down. 0 = Do not pull AUXFAULTB low.
b[0]	<code>Mfr_auxfaultb_uv_fault_response_chan0</code>	Response to channel 0 $V_{OUT_UV_FAULT}$. 1 = Pull AUXFAULTB low via fast pull-down. 0 = Do not pull AUXFAULTB low.

PMBus COMMAND DESCRIPTION

When `Mfr_config_track_en` is enabled the channel is reconfigured to:

- Sequence down on fault, `VIN_OFF`, `SHARE_CLK` low or `RESTORE_USER_ALL`.
- Ignore UV during `TOFF_DELAY`. Note that ignoring UV during `TON_RISE` and `TON_MAX_FAULT` always happens regardless of how this bit is set.

The following example illustrates configuring an LTC2972 with one master channel and one slave.

Master channel 0

`TON_DELAY = Ton_delay_master`

`TON_RISE = Ton_rise_master`

`TOFF_DELAY = Toff_delay_master`

`Mfr_config_track_en = 0`

Slave channel 1

`TON_DELAY = Ton_delay_slave`

`TON_RISE = Ton_delay_master + Ton_rise_slave`

`TOFF_DELAY = Toff_delay_master + T_off_delay_slave`

`Mfr_config_track_en = 1`

Where:

`Ton_delay_master – Ton_delay_slave > RUN to TRACK setup time`

`Toff_delay_slave > time for master supply to fall.`

The system response to a control pin toggle is illustrated in Figure 17.

The system response to a UV fault on a slave channel is illustrated in Figure 18.

PMBus COMMAND DESCRIPTION

MFR_CONFIG_ALL_LTC2972

This command is used to configure parameters that are common to both channels on the IC. They may be set or reviewed from any PAGE setting.

MFR_CONFIG_ALL_LTC2972 Data Contents

BIT(S)	SYMBOL	OPERATION
b[15:13]	Reserved	Don't care. Always returns 0.
b[12]	Mfr_config_all_en_short_cycle_fault	Enable short cycle fault detection. See Mfr_status_2_short_cycle_fault on page 74 for more information. 0: Issuing an ON before prior OFF is complete will not cause a fault. 1: Issuing an ON before prior OFF is complete will cause a fault.
b[11]	Mfr_config_all_pwrzd_off_uses_uv	Selects PWRGD de-assertion source for both channels. 0: PWRGD is de-asserted based on V_{OUT} being below or equal to POWER_GOOD_OFF. This option uses the ADC. Response time is approximately 100ms to 200ms. 1: PWRGD is de-asserted based on V_{OUT} being below or equal to VOUT_UV_LIMIT. This option uses the high speed supervisor. Response time is approximately 12 μ s.
b[10]	Reserved	Don't care.
b[9]	Reserved	Don't care. Always returns 0.
b[8]	Reserved	Don't care. Always returns 0.
b[7]	Mfr_config_all_fault_log_enable	Enable fault logging to EEPROM in response to Fault. 0: Fault logging to EEPROM is disabled. 1: Fault logging to EEPROM is enabled.
b[6]	Mfr_config_all_vin_on_clr_faults_en	Allow VIN_ON rising edge to clear all latched faults. 0: VIN_ON clear faults feature is disabled. 1: VIN_ON clear faults feature is enabled.
b[5]	Mfr_config_all_control1_pol	Selects active polarity of CONTROL1 pin 0: Active low (pull pin low to start unit). 1: Active high (pull pin high to start unit).
b[4]	Mfr_config_all_control0_pol	Selects active polarity of CONTROL0 pin 0: Active low (pull pin low to start unit). 1: Active high (pull pin high to start unit).
b[3]	Mfr_config_all_vin_share_enable	Allow this unit to hold Share-clock pin low when V_{IN} has not risen above VIN_ON or has fallen below VIN_OFF. When enabled this unit will also turn both channels off in response to Share-clock being held low. 0: Share-clock inhibit is disabled. 1: Share-clock inhibit is enabled.
b[2]	Mfr_config_all_pec_en	PMBus packet error checking enable. 0: PEC is accepted but not required. 1: PEC is enabled.
b[1]	Mfr_config_all_longer_pmbus_timeout	Increase PMBus timeout interval by a factor of 8. Recommended for fault logging. 0: PMBus timeout is not multiplied by a factor of 8. 1: PMBus timeout is multiplied by a factor of 8.
b[0]	Reserved	Always set to 1.

PMBus COMMAND DESCRIPTION

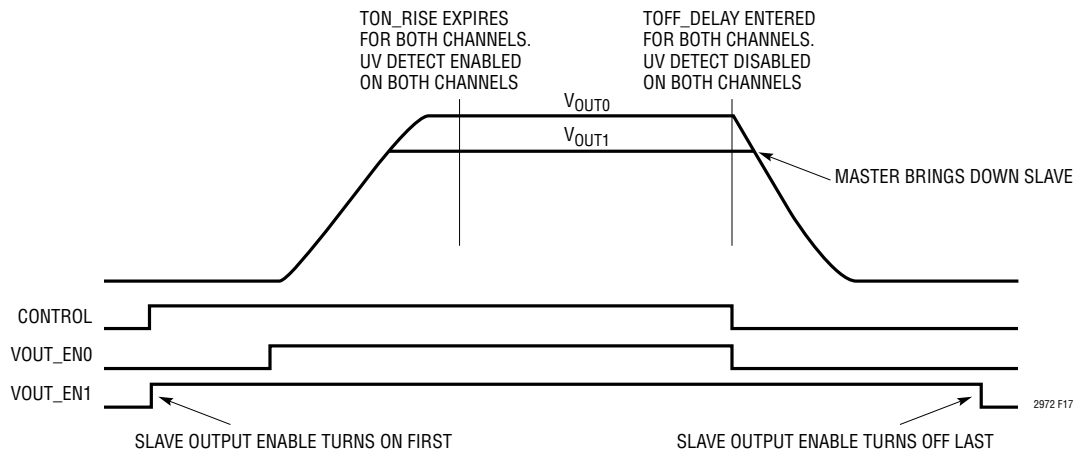

Figure 17. Control Pin Tracking All Supplies Up And Down

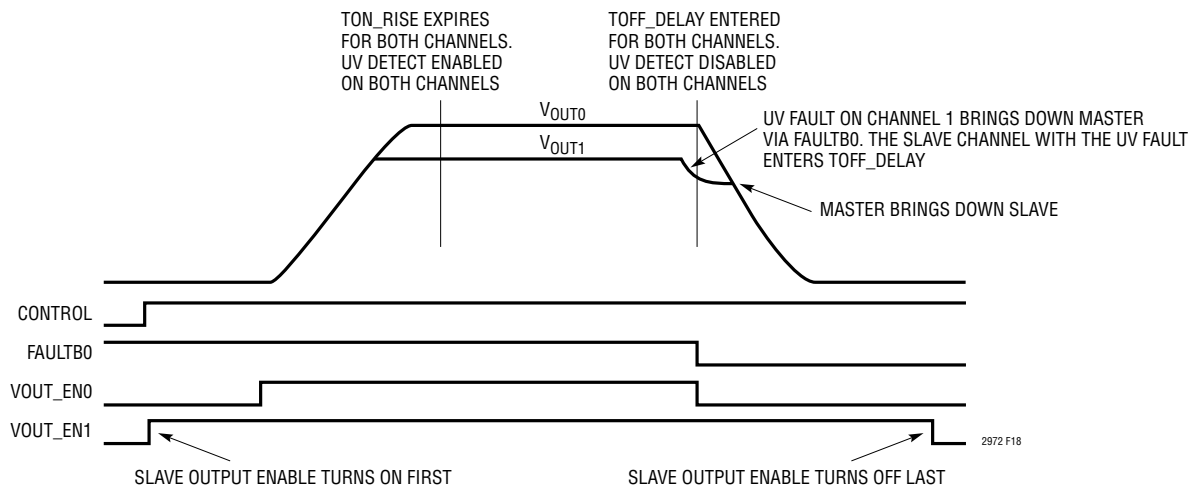

Figure 18. Fault on Channel 1 Tracking All Supplies Down

PMBus COMMAND DESCRIPTION

PROGRAMMING USER EEPROM SPACE

COMMAND NAME	CMD CODE	DESCRIPTION	TYPE	PAGED	FORMAT	UNITS	EEPROM	DEFAULT VALUE	REF PAGE
STORE_USER_ALL	0x15	Store entire operating memory to EEPROM.	Send Byte	N				NA	46
RESTORE_USER_ALL	0x16	Restore entire operating memory from EEPROM.	Send Byte	N				NA	46
MFR_EE_UNLOCK	0xBD	Unlock user EEPROM for access by MFR_EE_ERASE and MFR_EE_DATA commands.	R/W Byte	N	Reg			NA	47
MFR_EE_ERASE	0xBE	Initialize user EEPROM for bulk programming by MFR_EE_DATA.	R/W Byte	N	Reg			NA	47
MFR_EE_DATA	0xBF	Data transferred to and from EEPROM using sequential PMBus word reads or writes. Supports bulk programming.	R/W Word	N	Reg			NA	47

STORE_USER_ALL and RESTORE_USER_ALL

STORE_USER_ALL, RESTORE_USER_ALL commands provide access to User EEPROM space. Once a command is stored in User EEPROM, it will be restored with explicit restore command, when the part emerges from power-on reset after power is applied, or after toggling the Reset pin. While either of these commands is being processed, the part will indicate it is busy, see Response When Part Is Busy on page [48](#).

STORE_USER_ALL. Issuing this command will store all operating memory commands with a corresponding EEPROM memory location.

RESTORE_USER_ALL. Issuing this command will restore all commands from EEPROM Memory. It is recommended that this command not be executed while a unit is enabled since all monitoring is suspended while the EEPROM is transferred to operating memory, and intermediate values from EEPROM may not be compatible with the values initially stored in operating memory.

Bulk Programming the User EEPROM Space

The MFR_EE_UNLOCK, MFR_EE_ERASE and MFR_EE_DATA commands provide a method for 3rd party EEPROM programming houses and end users to easily program the LTC2972 independent of any order dependencies or delays between PMBus commands. All data transfers are directly to and from the EEPROM and do not affect the volatile RAM space currently configuring the device.

The first step is to program a master reference part with the desired configuration. MFR_EE_UNLOCK and MFR_EE_DATA are then used to read back all the data in User EEPROM space as sequential words. This information is stored to the master programming HEX file. Subsequent parts may be cloned to match the master part using MFR_EE_UNLOCK, MFR_EE_ERASE and MFR_EE_DATA to transfer data from the master HEX file. These commands operate directly on the EEPROM independent of the part configurations stored in RAM space. During EEPROM access the part will indicate that it is busy as described below.

In order to support simple programming fixtures the bulk programming features only uses PMBus word and byte commands. The MFR_UNLOCK configures the appropriate access mode and resets an internal address pointer allowing a series of word commands to behave as a block read or write with the address pointer being incremented after each operation. PEC use is optional and is configured by the MFR_EE_UNLOCK operation.

PMBus COMMAND DESCRIPTION

MFR_EE_UNLOCK

The MFR_EE_UNLOCK command prevents accidental EEPROM access in normal operation and configures the required EEPROM bulk programming mode for bulk initialization, sequential writes, or reads. MFR_EE_UNLOCK augments the protection provided by write protect. Upon unlocking the part for the required operation, an internal address pointer is reset allowing a series of MFR_EE_DATA reads or writes to sequentially transfer data, similar to a block read or block write. The MFR_EE_UNLOCK command can clear or set PEC mode based on the desired level of error protection. An MFR_EE_UNLOCK sequence consists of writing two or three unlock codes as described below. The following table documents the allowed sequences. Writing a non-supported sequence locks the part. Reading MFR_EE_UNLOCK returns the last byte written or zero if the part is locked.

MFR_EE_UNLOCK Data Contents

BIT(S)	SYMBOL	OPERATION
b[7:0]	Mfr_ee_unlock[7:0]	<p>To unlock user EEPROM space for Mfr_ee_erase and Mfr_ee_data read or write operations with PEC allowed: Write 0x2B followed by 0xD4.</p> <p>To unlock user EEPROM space for Mfr_ee_erase and Mfr_ee_data read or write operations with PEC required: Write 0x2B followed by 0xD5.</p> <p>To unlock user and manufacturer EEPROM space for Mfr_ee_data read only operations with PEC allowed: Write 0x2B, followed by 0x91 followed by 0xE4.</p> <p>To unlock user and manufacturer EEPROM space for Mfr_ee_data read only operations with PEC required: Write 0x2B, followed by 0x91 followed by 0xE5.</p>

MFR_EE_ERASE

The MFR_EE_ERASE command is used to erase the entire contents of the user EEPROM space and configures this space to accept new program data. Writing values other than 0x2B will lock the part. Reads return the last value written.

MFR_EE_ERASE Data contents

BIT(S)	SYMBOL	OPERATION
b[7:0]	Mfr_ee_erase[7:0]	<p>To erase the user EEPROM space and configure to accept new data:</p> <ol style="list-style-type: none"> 1) Use the appropriate Mfr_ee_unlock sequence to configure for Mfr_ee_erase commands with or without PEC. 2) Write 0x2B to Mfr_ee_erase. <p>The part will indicate it is busy erasing the EEPROM by the mechanism detailed below.</p>

MFR_EE_DATA

The MFR_EE_DATA command allows the user to transfer data directly to or from the EEPROM without affecting RAM space.

To read the user EEPROM space issue the appropriate Mfr_ee_unlock command and perform Mfr_ee_data reads until the EEPROM has been completely read. Extra reads will lock the part and return zero. The first read returns the 16-bit EEPROM packing revision ID that is stored in ROM. The second read returns the number of 16-bit words available; this is the number of reads or writes to access all memory locations. Subsequent reads return EEPROM data starting with lowest address.

To write to the user EEPROM space issue the appropriate Mfr_ee_unlock and Mfr_ee_erase commands followed by successive Mfr_ee_data word writes until the EEPROM is full. Extra writes will lock the part. The first write is to the lowest address.

PMBus COMMAND DESCRIPTION

Mfr_ee_data reads and writes must not be mixed.

MFR_EE_DATA Data Contents

BIT(S)	SYMBOL	OPERATION
b[15:0]	Mfr_ee_data[15:0]	<p>To read user space</p> <ol style="list-style-type: none"> 1) Use the appropriate Mfr_ee_unlock sequence to configure for Mfr_ee_data commands with or without PEC. 2) Read Mfr_ee_data[0] = PackingId (MFR Specific ID). 3) Read Mfr_ee_data[1] = NumberOfUserWords (total number of 16-bit word available). 4) Read Mfr_ee_data[2] through Mfr_ee_data[NumberOfWord+1] (User EEPROM data contents). <p>To write user space</p> <ol style="list-style-type: none"> 1) Initialize the user memory using the sequence described for the MFR_EE_ERASE command. 2) Use the appropriate Mfr_ee_unlock sequence to configure for Mfr_ee_data commands with or without PEC. 3) Write Mfr_ee_data[0] through Mfr_ee_data[NumberOfWord-1] (User EEPROM data content to be written). <p>The part will indicate it is busy erasing the EEPROM by the mechanism detailed below.</p>

Response When Part Is Busy

The part will indicate it is busy accessing the EEPROM by:

- 1) Asserting low the Mfr_common_busy of the MFR_COMMON register. This byte can always be read and will never NACK a byte read request even if the part is busy.
- 2) NACKing commands other than MFR_COMMON.
- 3) Asserting ALERTB low if any command other than MFR_COMMON are issued.

MFR_EE Erase and Write Programming Time

The program time per word is typically 0.51ms and will require spacing the I²C/SMBus writes at greater than 0.51ms to guarantee the write has completed. The Mfr_ee_erase command takes approximately 400ms. We recommend using MFR_COMMON for handshaking.

INPUT VOLTAGE COMMANDS AND LIMITS

COMMAND NAME	CMD CODE	DESCRIPTION	TYPE	PAGED	FORMAT	UNITS	EEPROM	DEFAULT VALUE	REF PAGE
VIN_ON	0x35	Input voltage above which power conversion can be enabled.	R/W Word	N	L11	V	Y	10.0 0xD280	49
VIN_OFF	0x36	Input voltage below which power conversion is disabled. Both V _{OUT_ENn} pins go off immediately or sequence off after TOFF_DELAY (See Mfr_config_track_en).)	R/W Word	N	L11	V	Y	9.0 0xD240	49
VIN_OV_FAULT_LIMIT	0x55	Input overvoltage fault limit measured at VIN_SNS pin.	R/W Word	N	L11	V	Y	15.0 0xD3C0	49
VIN_OV_WARN_LIMIT	0x57	Input overvoltage warning limit measured at VIN_SNS pin.	R/W Word	N	L11	V	Y	14.0 0xD380	49
VIN_UV_WARN_LIMIT	0x58	Input undervoltage warning limit measured at VIN_SNS pin.	R/W Word	N	L11	V	Y	0 0x8000	49
VIN_UV_FAULT_LIMIT	0x59	Input undervoltage fault limit measured at VIN_SNS pin.	R/W Word	N	L11	V	Y	0 0x8000	49

PMBus COMMAND DESCRIPTION

VIN_ON, VIN_OFF, VIN_OV_FAULT_LIMIT, VIN_OV_WARN_LIMIT, VIN_UV_WARN_LIMIT and VIN_UV_FAULT_LIMIT

These commands provide voltage supervising limits for the input voltage V_{IN_SNS} .

INPUT CURRENT AND ENERGY

COMMAND NAME		DESCRIPTION	TYPE	PAGED	FORMAT	UNITS	EEPROM	DEFAULT VALUE	REF PAGE
MFR_EIN	0xC0	Input energy data bytes.	R Block	N	Reg			NA	49
MFR_EIN_CONFIG	0xC1	Configuration register for energy and input current.	R/W Byte	N	Reg		Y	0	50
MFR_IIN_CAL_GAIN_TC	0xC3	Temperature coefficient applied to IIN_CAL_GAIN.	R/W Word	N	CF	ppm	Y	0x0	51
MFR_IIN_CAL_GAIN	0xE8	The nominal resistance of the current sense element in mΩ.	R/W Word	N	L11	mΩ	Y	1.0 0xBA00	51
MFR_CLEAR_ENERGY	0xCC	Clear MFR_EIN time and energy values	Send Byte	N				NA	51

Energy Measurement and Reporting

Input energy measurement and monitoring supports the following:

- Input energy derived from the accumulated product of READ_VIN and READ_IIN.
- Reporting input energy value as a 48-bit integer in mJ. Returning value in Joules eliminates the need for the host to manage time.
- Reporting input energy time as a 48-bit integer in ms, where input energy time is the elapsed time since energy monitoring was last reset.
- Resetting time and energy accumulators whenever MFR_EIN_CONFIG or MFR_CLEAR_ENERGY is written.
- Wrapping of time and energy accumulators when full.
- An optional HD mode allowing the user to give priority to energy measurement by forcing the ADC to measure READ_VIN and READ_IIN between every other ADC measurement.
- Reporting energy and time values coherently.
- Ability to decrement energy to prevent rectification and accumulation of noise when the channel is off. Energy is not allowed to decrement below zero.

MFR_EIN

Read only. This 12-byte data block returns the input energy value and time. Once the block read starts, MFR_EIN updates are suspended until the block read completes. However, energy and time continue to accumulate internally during block reads.

PMBus COMMAND DESCRIPTION

Table 4. MFR_EIN Data Block Contents

DATA	BYTE*	DESCRIPTION
Energy_value [7:0]	0	Energy Value in mJ. This is the accumulated energy since Mfr_ein_config or Mfr_clear_energy was last written.
Energy_value [15:8]	1	
Energy_value [23:16]	2	
Energy_value [31:24]	3	
Energy_value [39:32]	4	
Energy_value [47:40]	5	
Energy_time [7:0]	6	Energy Time in ms. This is the elapsed time since Mfr_ein_config or Mfr_clear_energy was last written.
Energy_time [15:8]	7	
Energy_time [23:16]	8	
Energy_time [31:24]	9	
Energy_time [39:32]	10	
Energy_time [47:40]	11	

MFR_EIN_CONFIG

This command configures energy and input current related parameters.

MFR_EIN_CONFIG Data Contents

BIT(S)	SYMBOL	OPERATION
b[7:3]	Mfr_ein_config_reserved	Don't care. Always returns 0.
b[2]	Mfr_ein_config_hd	Optimize ADC polling sequence for higher definition input energy measurement. 0: Standard ADC polling sequence 1: Read_vin and Read_iin measurements are interleaved between every other ADC measurement.
b[1:0]	Mfr_ein_config_iin_range	Input sense amplifier range setting. 0: High Range 1: Medium Range 2: Low Range 3: Reserved The range sets the Full-Scale Input Voltage Range (FS_IIN). Lower range settings have lower input referred noise. See Measuring Input Current in the Applications section for additional details.

PMBus COMMAND DESCRIPTION

MFR_IIN_CAL_GAIN

The MFR_IIN_CAL_GAIN command is used to set the ratio of the voltage at the input current sense pins to the sensed current. For devices using a fixed current sense resistor, it is the same value as the resistance of the sense resistor (units are expressed in mΩ). MFR_IIN_CAL_GAIN is internally limited to values between 0.01mΩ to 1,000mΩ. The register readback value always returns what was last written and does not reflect internal limiting.

Calculations using IIN_CAL_GAIN are:

$$\text{READ_IIN} = \frac{V_{\text{IIN_SNSPn}} - V_{\text{IIN_SNSMn}}}{(\text{MFR_IIN_CAL_GAIN}) \cdot T_{\text{CORRECTION}}}$$

where:

$$T_{\text{CORRECTION}} = [1 + \text{MFR_IIN_CAL_GAIN_TC} \cdot 1\text{E-6} \cdot (\text{READ_TEMPERATURE_2} - 25.0)]$$

Note:

$T_{\text{CORRECTION}}$ is limited by hardware to a value between 0.25 and 4.0.

READ_TEMPERATURE_2 is the internal die temperature.

Mfr_ein_config_iin_range[1:0] may be used to minimize noise in systems with low sense resistor values.

MFR_IIN_CAL_GAIN_TC

The MFR_IIN_CAL_GAIN_TC sets the temperature coefficient of the MFR_IIN_CAL_GAIN register value in ppm/°C. This command uses the internal die temperature.

Refer to MFR_IIN_CAL_GAIN for details on proper usage.

MFR_IIN_CAL_GAIN_TC Data Contents

BIT(S)	SYMBOL	OPERATION
b[15:0]	Mfr_iin_cal_gain_tc	16-bit twos complement integer representing the temperature coefficient. Value = Y where Y = b[15:0] is a twos complement number. Example: Mfr_iin_cal_gain_tc = 3900ppm For b[15:0] = 0x0F3C, Value = 3900

MFR_CLEAR_ENERGY

This send byte command clears the accumulated energy and time value in MFR_EIN and can be written even when the LTC2972 is write-protected with level 2 protection. The LTC2972 may internally delay the application of this command by up to $t_{\text{UPDATE_ADC}}$, in order to avoid corrupting an ongoing energy calculation.

PMBus COMMAND DESCRIPTION

OUTPUT VOLTAGE COMMANDS AND LIMITS

COMMAND NAME	CMD CODE	DESCRIPTION	TYPE	PAGED	FORMAT	UNITS	EEPROM	DEFAULT VALUE	REF PAGE
VOUT_MODE	0x20	Output voltage data format and mantissa exponent (2^{-13}).	R Byte	Y	Reg			0x13	52
VOUT_COMMAND	0x21	Servo target. Nominal DC/DC converter output voltage setpoint.	R/W Word	Y	L16	V	Y	1.0 0x2000	53
VOUT_MAX	0x24	Upper limit on the output voltage the unit can command regardless of any other commands.	R/W Word	Y	L16	V	Y	4.0 0x8000	53
VOUT_MARGIN_HIGH	0x25	Margin high DC/DC converter output voltage setting.	R/W Word	Y	L16	V	Y	1.05 0x219A	53
VOUT_MARGIN_LOW	0x26	Margin low DC/DC converter output voltage setting.	R/W Word	Y	L16	V	Y	0.95 0x1E66	53
VOUT_OV_FAULT_LIMIT	0x40	Output overvoltage fault limit.	R/W Word	Y	L16	V	Y	1.1 0x2333	53
VOUT_OV_WARN_LIMIT	0x42	Output overvoltage warning limit.	R/W Word	Y	L16	V	Y	1.075 0x2266	53
VOUT_UV_WARN_LIMIT	0x43	Output undervoltage warning limit.	R/W Word	Y	L16	V	Y	0.925 0x1D9A	53
VOUT_UV_FAULT_LIMIT	0x44	Output undervoltage fault limit. Used for Ton_max_fault and PWRGD pin de-assertion.	R/W Word	Y	L16	V	Y	0.9 0x1CCD	53
POWER_GOOD_ON	0x5E	Output voltage at or above which the PWRGD pin should be asserted.	R/W Word	Y	L16	V	Y	0.96 0x1EB8	53
POWER_GOOD_OFF	0x5F	Output voltage at or below which the PWRGD pin should be de-asserted when Mfr_config_all_pwrqd_off_uses_uv is clear.	R/W Word	Y	L16	V	Y	0.94 0x1E14	53
MFR_VOUT_DISCHARGE_THRESHOLD	0xE9	Coefficient used to multiply VOUT_COMMAND in order to determine V_{OUT} off threshold voltage.	R/W Word	Y	L11		Y	2.0 0xC200	53
MFR_DAC	0xE0	Manufacturer register that contains the code of the 10-bit DAC.	R/W Word	N	Reg			0x0000	53
MFR_DAC_STARTUP	0xCD	DAC Output Code Used At Start-up	R/W Word	Y	Reg		Y	0x0000	54

VOUT_MODE

This command is read only and specifies the mode and exponent for all commands with a L16 data format. See Data Formats on page 27.

VOUT_MODE Data Contents

BIT(S)	SYMBOL	OPERATION
b[7:5]	Vout_mode_type	Reports linear mode. Hard-wired to 000b.
b[4:0]	Vout_mode_parameter	Linear mode exponent. 5-bit two's complement integer. Hardwired to 0x13 (-13 decimal).

PMBus COMMAND DESCRIPTION

VOUT_COMMAND, VOUT_MAX, VOUT_MARGIN_HIGH, VOUT_MARGIN_LOW, VOUT_OV_FAULT_LIMIT, VOUT_OV_WARN_LIMIT, VOUT_UV_WARN_LIMIT, VOUT_UV_FAULT_LIMIT, POWER_GOOD_ON and POWER_GOOD_OFF

These commands provide various servo, margining and supervising limits for a channel's output voltage.

MFR_VOUT_DISCHARGE_THRESHOLD

This register contains the coefficient that multiplies `VOUT_COMMAND` in order to determine the OFF threshold voltage for the associated output. If the output voltage has not decayed below `MFR_VOUT_DISCHARGE_THRESHOLD • VOUT_COMMAND` prior to the channel being commanded to enter/re-enter the ON state, the `Status_mfr_discharge` bit in the `STATUS_MFR_SPECIFIC` register will be set and the `ALERTB` pin will be asserted low. In addition, the channel will not enter the ON state until the output has decayed below its off-threshold voltage. Setting this to a value greater than 1.0 effectively disables `DISCHARGE_THRESHOLD` checking, allowing the channel to turn back on even if it has not decayed at all.

Other channels can be held-off if a particular output has failed to discharge by using the bidirectional `FAULTBn` pins (refer to the `MFR_FAULTBn_RESPONSE` and `MFR_FAULTBn_PROPOGATE` registers).

MFR_DAC_STARTUP

This command register programs the 10-bit DAC to a specific DAC code when a channel is enabled with the DAC set to connect immediately and servo is disabled (`MFR_CONFIG_LTC2972 b[5:4] = 10b`). This value is loaded from EEPROM at power-on-reset or after a `RESTORE_USER_ALL` command. After loading, all subsequent DAC values are set by writing to the `MFR_DAC` command register. If soft-connect mode is enabled, the value in this register is ignored.

MFR_DAC_STARTUP Data Contents

BIT(S)	SYMBOL	OPERATION
b[15:10]	Reserved	Read only, always returns 0.
b[9:0]	<code>Mfr_dac_startup_val</code>	DAC code value.

MFR_DAC

This command register allows the user to directly program the 10-bit DAC. Manual DAC writes require the channel to be in the ON state, `TON_RISE` to have expired and `MFR_CONFIG_LTC2972 b[5:4] = 10b` or `11b`. Writing `MFR_CONFIG_LTC2972 b[5:4] = 10b` commands the DAC to hard connect with the value in `Mfr_dac_direct_val`. Writing `b[5:4] = 11b` commands the DAC to soft connect. Once the DAC has soft connected, `Mfr_dac_direct_val` returns the value that allowed the DAC to be connected without perturbing the power supply. `MFR_DAC` writes are ignored when `MFR_CONFIG_LTC2972 b[5:4] = 00b` or `01b`.

PMBus COMMAND DESCRIPTION

MFR_DAC Data Contents

BIT(S)	SYMBOL	OPERATION
b[15:10]	Reserved	Read only, always returns 0.
b[9:0]	Mfr_dac_direct_val	DAC code value.

OUTPUT CURRENT COMMANDS AND LIMITS

COMMAND NAME	CMD CODE	DESCRIPTION	TYPE	PAGED	FORMAT	UNITS	EEPROM	DEFAULT VALUE	REF PAGE
IOUT_CAL_GAIN	0x38	The nominal resistance of the current sense element in mΩ.	R/W Word	Y	L11	mΩ	Y	1.0 0xBA00	54
IOUT_CAL_OFFSET	0x39	Offset applied to the current sense measurement in Amps.	R/W Word	Y	L11	A	Y	0.0 0x8000	54
IOUT_OC_WARN_LIMIT	0x4A	Output overcurrent warning limit.	R/W Word	Y	L11	A		5.0 0xCA80	54
MFR_IOUT_CAL_GAIN_TC	0xF6	Temperature coefficient applied to IOUT_CAL_GAIN.	R/W Word	Y	CF	ppm	Y	0x0	54

IOUT_CAL_GAIN and IOUT_CAL_OFFSET

The IOUT_CAL_GAIN command is used to set the ratio of the voltage at the current sense pins to the sensed current. For devices using a fixed current sense resistor, it is the same value as the resistance of the resistor (units are expressed in mΩ). IOUT_CAL_GAIN is internally limited to values between 0.01mΩ to 1,000mΩ. The register readback value always returns what was last written and does not reflect internal limiting. IOUT_CAL_OFFSET is used to add a current offset from the READ_IOUT results.

Calculations using IOUT_CAL_GAIN and IOUT_CAL_OFFSET are:

$$T_{\text{CORRECTION}} = (1 + \text{MFR_IOUT_CAL_GAIN_TC} \cdot 1\text{E-}6 \cdot (\text{READ_TEMPERATURE_1} + \text{MFR_T_SELF_HEAT} - 25.0))$$

$$\text{READ_IOUT} = \frac{V_{\text{IOUT_SNSPn}} - V_{\text{IOUT_SNSMn}}}{(\text{IOUT_CAL_GAIN}) \cdot T_{\text{CORRECTION}}} + \text{IOUT_CAL_OFFSET}$$

Note: $T_{\text{CORRECTION}}$ is limited by hardware to a value between 0.25 and 4.0.

READ_TEMPERATURE_2 is substituted for READ_TEMPERATURE_1 if the associated T_{SENSE} network fails to detect a valid temperature. See READ_TEMPERATURE_1 for more information.

IOUT_OC_WARN_LIMIT

The IOUT_OC_WARN_LIMIT is measured by the LTC2972's ADC.

MFR_IOUT_CAL_GAIN_TC

The MFR_IOUT_CAL_GAIN_TC is a paged command that sets the temperature coefficient of the IOUT_CAL_GAIN register value in ppm/°C. This command uses the temperature measured by the external temperature diode for the associated page.

Refer to IOUT_CAL_GAIN for details on proper usage.

PMBus COMMAND DESCRIPTION

MFR_IOUT_CAL_GAIN_TC Data Contents

BIT(S)	SYMBOL	OPERATION
b[15:0]	Mfr_iout_cal_gain_tc	16-bit twos complement integer representing the temperature coefficient. Value = Y where Y = b[15:0] is a twos complement. Example: Mfr_iout_cal_gain_tc = 3900ppm For b[15:0] = 0x0F3C Value = 3900

EXTERNAL TEMPERATURE COMMANDS AND LIMITS

COMMAND NAME	CMD CODE	DESCRIPTION	TYPE	PAGED	FORMAT	UNITS	EEPROM	DEFAULT VALUE	REF PAGE
OT_FAULT_LIMIT	0x4F	Overtemperature fault limit setting for the external temperature sensor.	R/W Word	Y	L11	°C	Y	65.0 0xEA08	56
OT_WARN_LIMIT	0x51	Overtemperature warning limit for the external temperature sensor	R/W Word	Y	L11	°C	Y	60.0 0xE3C0	56
UT_WARN_LIMIT	0x52	Undertemperature warning limit for the external temperature sensor.	R/W Word	Y	L11	°C	Y	0 0x8000	56
UT_FAULT_LIMIT	0x53	Undertemperature fault limit for the external temperature sensor.	R/W Word	Y	L11	°C	Y	-5.0 0xCD80	56
MFR_TEMP_1_GAIN	0xF8	Inverse of external diode temperature non ideality factor. One LSB = 2^{-14} .	R/W Word	Y	CF		Y	1 0x4000	56
MFR_TEMP_1_OFFSET	0xF9	Offset value for the external temperature.	R/W Word	Y	L11	°C	Y	0 0x8000	56
MFR_T_SELF_HEAT	0xB8	Calculated temperature rise due to self-heating of output current sense device above value measured by external temperature sensor.	R Word	Y	L11	°C		NA	56
MFR_IOUT_CAL_GAIN_TAU_INV	0xB9	Inverse of time constant for Mfr_t_self_heat changes scaled by 4 • tCONV_SENSE.	R/W Word	Y	L11		Y	0.0 0x8000	56
MFR_IOUT_CAL_GAIN_THETA	0xBA	Thermal resistance from inductor core to point measured by external temperature sensor.	R/W Word	Y	L11	°C/W	Y	0.0 0x8000	56

PMBus COMMAND DESCRIPTION

OT_FAULT_LIMIT, OT_WARN_LIMIT, UT_WARN_LIMIT and UT_FAULT_LIMIT

These commands provide supervising limits for temperature as measured by the external diode.

MFR_TEMP_1_GAIN and MFR_TEMP_1_OFFSET

The MFR_TEMP_1_GAIN command specifies the inverse of the temperature sensor ideality factor. The MFR_TEMP_1_OFFSET allows an offset to be applied to the measured temperature.

Calculations using these paged commands are:

$$\text{READ_TEMPERATURE_1} = T_{\text{EXT}} \cdot \text{MFR_TEMP_1_GAIN} - 273.15 + \text{MFR_TEMP_1_OFFSET}$$

where:

$$T_{\text{EXT}} = \text{Measured external temperature in degrees Kelvin.}$$

READ_TEMPERATURE_2 is substituted for READ_TEMPERATURE_1 if the associated T_{SENSE} network fails to detect a valid temperature. Under these conditions MFR_TEMP_1_GAIN and MFR_TEMP_1_OFFSET will have no effect. See READ_TEMPERATURE_1 for more information.

MFR_TEMP_1_GAIN Data Contents

BIT(S)	SYMBOL	OPERATION
b[15:0]	Mfr_temp_1_gain[15:0]	16-bit integer representing inverse of temperature non-ideality factor. Value = $Y \cdot 2^{14}$ where $Y = b[15:0]$ is an unsigned integer. Example: MFR_TEMP_1_GAIN = 1.0 For b[15:0] = 0x4000 Value = $16384 \cdot 2^{-14} = 1.0$

MFR_T_SELF_HEAT, MFR_IOUT_CAL_GAIN_TAU_INV and MFR_IOUT_CAL_GAIN_THETA

The LTC2972 uses an innovative (US patent 8920026) algorithm to dynamically model the temperature rise from the external temperature sensor to the inductor core. This temperature rise is called MFR_T_SELF_HEAT and is used to calculate the final temperature correction required by IOUT_CAL_GAIN. The temperature rise is a function of the power dissipated in the inductor DCR, the thermal resistance from the inductor core to the remote temperature sensor and the thermal time constant of the inductor to board system. The algorithm simplifies the placement requirements for the external temperature sensor and compensates for the significant steady state and transient temperature error from the inductor core to the primary inductor heat sink.

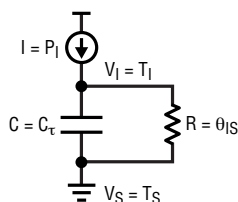

- P_i = CURRENT REPRESENTING THE POWER DISSIPATED BY THE INDUCTOR ($V_{\text{DCR}} \cdot \text{READ_IOUT}$ WHERE $V_{\text{DCR}} = (V_{\text{ISENSEP}} - V_{\text{ISENSM}})$)
- C_t = CAPACITANCE REPRESENTING THERMAL HEAT CAPACITY OF THE INDUCTOR (INCLUDED IN MFR_IOUT_CAL_GAIN_TAU_INV)
- T_1 = VOLTAGE REPRESENTING THE TEMPERATURE OF THE INDUCTOR
- θ_{IS} = RESISTANCE REPRESENTING THE THERMAL RESISTANCE FROM THE DCR TO THE REMOTE TEMPERATURE SENSOR (MFR_IOUT_CAL_GAIN_THETA)
- T_s = VOLTAGE REPRESENTING THE TEMPERATURE AT THE REMOTE TEMPERATURE SENSOR

2972 F19

Figure 19. Electronic Analogy for Inductor Temperature Model

PMBus COMMAND DESCRIPTION

The best way to understand the self-heating effect inside the inductor is to model the system using the circuit analogy of Figure 19. The 1st order differential equation for the above model may be approximated by the following difference equation:

$$P_I - T_I/\theta_{IS} = C_\tau \Delta T_I/\Delta t \text{ (Eq1) (when } T_S = 0)$$

from which:

$$\Delta T_I = \Delta t (P_I \theta_{IS} - T_I)/(\theta_{IS} C_\tau) \text{ (Eq2) or}$$

$$\Delta T_I = (P_I \theta_{IS} - T_I) \cdot \tau_{INV} \text{ (Eq3)}$$

where

$$\tau_{INV} = \Delta t/(\theta_{IS} C_\tau) \text{ (Eq4)}$$

and Δt is the sample period of the external temperature ADC.

The LTC2972 implements the self-heating algorithm using Eq3 and Eq4 where:

$$\Delta T_I = \Delta MFR_T_SELF_HEAT$$

$$P_I = READ_IOUT \cdot (V_{ISENSEP} - V_{ISENSEM})$$

$$T_S = READ_TEMPERATURE_1$$

$$T_I = MFR_T_SELF_HEAT + T_S$$

$$\Delta t = 4 \cdot t_{CONV_SENSE} \text{ (One complete external temperature loop period)}$$

$$\tau_{INV} = MFR_IOUT_CAL_GAIN_TAU_INV$$

$$\theta_{IS} = MFR_IOUT_CAL_GAIN_THETA$$

Initially self heat is set to zero. After each temperature measurement self heat is updated to be the previous value of self heat incremented or decremented by $\Delta MFR_T_SELF_HEAT$.

The actual value of C_τ is not required. The important quantity is the thermal time constant $\tau_{INV} = (\theta_{IS} C_\tau)$. For example, if an inductor has a thermal time constant $\tau_{INV} = 5$ seconds then:

$$MFR_IOUT_CAL_GAIN_TAU_INV = (4 \cdot t_{CONV_SENSE})/5 = 4 \cdot 66\text{ms}/5\text{s} = 0.0528$$

Refer to the application section for more information on calibrating θ_{IS} and τ_{INV} .

READ_TEMPERATURE_2 is substituted for READ_TEMPERATURE_1 if the associated T_{SENSE} network fails to detect a valid temperature. Under these conditions $T_S = READ_TEMPERATURE_2$ and the self-heating correction is applied using the internal die temperature. See READ_TEMPERATURE_1 for more information.

MFR_T_SELF_HEAT Data Content

Bit(s)	Symbol	Operation
b[15:0]	Mfr_t_self_heat	Values are limited to the range 0°C to 50°C.

MFR_IOUT_CAL_GAIN_THETA Data Content

Bit(s)	Symbol	Operation
b[15:0]	Mfr_iout_cal_gain_theta	Values ≤ 0 set MFR_T_SELF_HEAT to zero.

PMBus COMMAND DESCRIPTION

MFR_IOUT_CAL_GAIN_TAU_INV Data Content

Bit(s)	Symbol	Operation
b[15:0]	Mfr_iout_cal_gain_tau_inv	Values ≤ 0 set MFR_T_SELF_HEAT to zero. Values ≥ 1 set MFR_T_SELF_HEAT to $MFR_IOUT_CAL_GAIN_THETA \cdot READ_IOUT \cdot (V_{ISENSEP} - V_{ISENSEM})$.

SEQUENCING TIMING LIMITS AND CLOCK SHARING

COMMAND NAME	CMD CODE	DESCRIPTION	TYPE	PAGED	FORMAT	UNITS	EEPROM	DEFAULT VALUE	REF PAGE
TON_DELAY	0x60	Time from CONTROL pin and/or OPERATION command = ON to V_{OUT_ENn} pin = ON.	R/W Word	Y	L11	ms	Y	1.0 0xBA00	58
TON_RISE	0x61	Time from when the V_{OUT_ENn} pin goes high until the LTC2972 optionally soft-connects its DAC and begins to servo the output voltage to the desired value.	R/W Word	Y	L11	ms	Y	10.0 0xD280	58
TON_MAX_FAULT_LIMIT	0x62	Maximum time from V_{OUT_ENn} pin on assertion that an UV condition will be tolerated before a TON_MAX_FAULT condition results.	R/W Word	Y	L11	ms	Y	15.0 0xD3C0	58
TOFF_DELAY	0x64	Time from CONTROL pin and/or OPERATION command = OFF to V_{OUT_ENn} pin = OFF	R/W Word	Y	L11	ms	Y	1.0 0xBA00	58
MFR_RESTART_DELAY	0xDC	Delay from actual CONTROL active edge to virtual CONTROL active edge.	R/W Word	N	L11	ms	Y	400 0xFB20	59

TON_DELAY, TON_RISE, TON_MAX_FAULT_LIMIT and TOFF_DELAY

These commands share the same format and provide sequencing and timer fault and warning delays in ms.

TON_DELAY sets the amount of time in milliseconds that a channel waits following the start of an ON sequence before its V_{OUT_EN} pin enables a DC/DC converter. This delay is counted using SHARE_CLK only.

TON_RISE sets the amount of time in ms that elapses after the power supply has been enabled until the LTC2972's DAC soft connects and servos the output voltage to the desired level if Mfr_dac_mode = 00b. This delay is counted using SHARE_CLK only.

TON_MAX_FAULT_LIMIT is the maximum amount of time that the power supply being controlled by the LTC2972 can attempt to power up the output without reaching the $V_{OUT_UV_FAULT_LIMIT}$. If it does not, then a TON_MAX_FAULT is declared. If the output reaches $V_{OUT_UV_FAULT_LIMIT}$ prior to TON_MAX_FAULT_LIMIT, the LTC2972 unmask the $V_{OUT_UV_FAULT_LIMIT}$ threshold. (Note that a value of zero means there is no limit to how long the power supply can attempt to bring up its output voltage.) This delay is counted using SHARE_CLK only.

TOFF_DELAY is the amount of time that elapses after the CONTROL pin and/or OPERATION command is de-asserted until the channel is disabled (soft-off). This delay is counted using SHARE_CLK if available, otherwise the internal oscillator is used.

TON_DELAY and TOFF_DELAY are internally limited to 13.1 seconds, and rounded to the nearest 10 μ s when smaller than 655ms, or rounded to the nearest 200 μ s when larger than 655ms. TON_RISE and TON_MAX_FAULT_LIMIT are internally limited to 655ms, and rounded to the nearest 10 μ s. The read value of these commands always returns what was last written and does not reflect internal limiting.

PMBus COMMAND DESCRIPTION

MFR_RESTART_DELAY

This command essentially sets the off time of a CONTROL pin initiated restart. If the CONTROL pin is toggled off for at least 10 μ s then on, all dependent channels are disabled, held off for a time = Mfr_restart_delay, then sequenced back on. CONTROL pin transitions whose OFF time exceeds Mfr_restart_delay are not affected by this command. A value of all zeros disables this feature. This delay is counted using SHARE_CLK only.

This delay is internally limited to 13.1 seconds, and rounded to the nearest 200 μ s. The read value of this command always returns what was last written and does not reflect internal limiting.

Clock Sharing

Multiple ADI PMBus devices can synchronize their clocks in an application by connecting together the open-drain SHARE_CLK input/outputs to a pull-up resistor as a wired OR. In this case the fastest clock will take over and synchronize all other chips to its falling edge.

SHARE_CLK can optionally be used to synchronize ON/OFF dependency on V_{IN} across multiple chips by setting the Mfr_config_all_vin_share_enable bit of the MFR_CONFIG_ALL register. When configured this way the chip will hold SHARE_CLK low when the unit is off for insufficient input voltage, and upon detecting that SHARE_CLK is held low the chip will disable both channels after a brief deglitch period. When the SHARE_CLK pin is allowed to rise, the chip will respond by beginning a start sequence. In this case the slowest VIN_ON detection will take over and synchronize other chips to its start sequence.

WATCHDOG TIMER AND POWER GOOD

COMMAND NAME	CMD CODE	DESCRIPTION	TYPE	PAGED	FORMAT	UNITS	EEPROM	DEFAULT VALUE	REF PAGE
MFR_PWRGD_EN	0xD4	Configuration that maps WDI/RESETB status and individual channel power good to the PWRGD pin.	R/W Word	N	Reg		Y	0x0000	62
MFR_POWERGOOD_ASSERTION_DELAY	0xE1	Power-good output assertion delay.	R/W Word	N	L11	ms	Y	100 0xEB20	62
MFR_WATCHDOG_T_FIRST	0xE2	First watchdog timer interval.	R/W Word	N	L11	ms	Y	0 0x8000	63
MFR_WATCHDOG_T	0xE3	Watchdog timer interval.	R/W Word	N	L11	ms	Y	0 0x8000	63
MFR_PG_CONFIG	0xCB	PG pin configuration	R/W Word	Y	Reg		Y	0xC046	60
MFR_PG_GPO	0xCE	PG pin output data register	R/W Byte	Y	Reg		Y	0x00	62

PMBus COMMAND DESCRIPTION

MFR_PG_CONFIG

The paged MFR_PG_CONFIG register defines the output operation of the per channel, open-drain, PG[1:0] pins. Fault signals selected to propagate to the PG pins are independent of their associated fault response masking. The V_{OUT} overvoltage and V_{OUT} undervoltage fast comparator signals are deglitched by the values set in the VOUT_OV_FAULT_RESPONSE and VOUT_UV_FAULT_RESPONSE registers respectively, in addition to the deglitching set by the MFR_PG_CONFIG register. Any programmed deglitching of the V_{OUT} overvoltage and undervoltage signals will be effectively disabled if the VOUT_EN signal is also propagated to PG[1:0] pins. During a power-on-reset, WDI reset, or RESTORE_USER_ALL, the PG pins will pull low until the LTC2972 has completed its initialization and all NVM data has been loaded into operating memory regardless of the MFR_PG_CONFIG register contents. The MFR_PG_CONFIG register is write protected in both Level 1 and Level 2 protection. The PG pins can also be configured as general purpose outputs allowing the user to directly control the PG pin state with values written to the MFR_PG_GPO register. The input pin state of the PG pins can be detected by reading the MFR_PADS register.

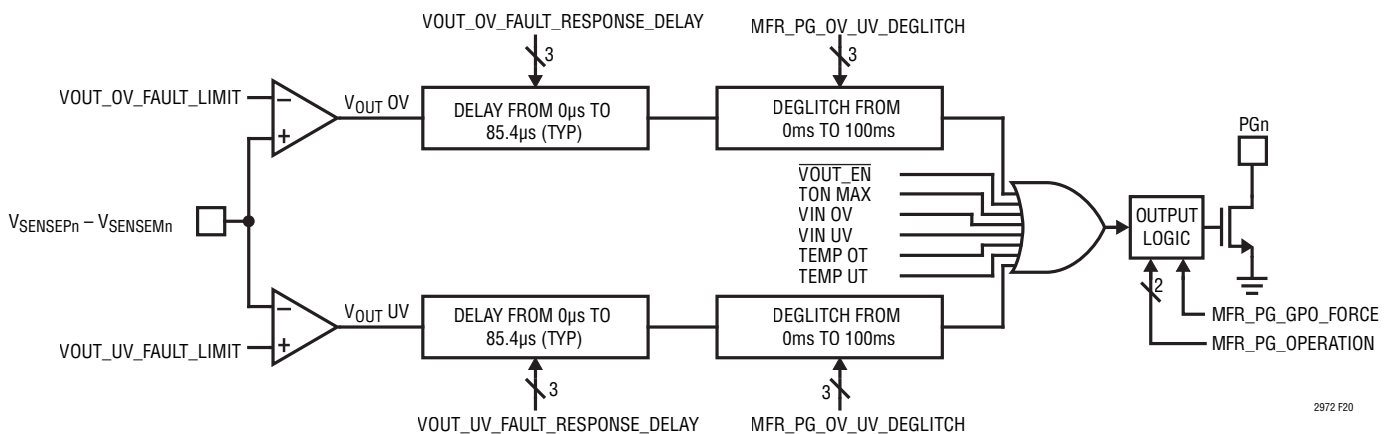

2972 F20

*SOME DETAILS OMITTED FOR CLARITY, ONLY ONE OF TWO CHANNELS SHOWN

Figure 20. PG Output Pin Functional Block Diagram

PMBus COMMAND DESCRIPTION

MFR_PG_CONFIG Data Contents

BIT(S)	SYMBOL	OPERATION
b[15]	Mfr_pg_fault_sel_vout_ov	1: Output overvoltage mapped to PG pin with additional deglitching equal to Mfr_pg_ov_uv_deglitch. Only applies if Mfr_pg_operation=10b or 11b. 0: Output overvoltage not mapped to PG pin.
b[14]	Mfr_pg_fault_sel_vout_uv	1: Output undervoltage mapped to PG pin with additional deglitching equal to Mfr_pg_ov_uv_deglitch. Only applies if Mfr_pg_operation=10b or 11b. 0: Output overvoltage not mapped to PG pin.
b[13]	Mfr_pg_fault_sel_iout_oc	Not supported
b[12]	Mfr_pg_fault_sel_iout_uc	Not supported
b[11]	Mfr_pg_fault_sel_temp_ot	1: Overtemperature mapped to PG pin. Only applies if Mfr_pg_operation=10b or 11b. 0: Overtemperature not mapped to PG pin.
b[10]	Mfr_pg_fault_sel_temp_ut	1: Undertemperature mapped to PG pin. Only applies if Mfr_pg_operation=10b or 11b. 0: Undertemperature not mapped to PG pin.
b[9]	Mfr_pg_fault_sel_vin_ov	1: Input overvoltage mapped to PG pin. Only applies if Mfr_pg_operation=10b or 11b. 0: Input overvoltage not mapped to PG pin.
b[8]	Mfr_pg_fault_sel_vin_uv	1: Input undervoltage mapped to PG pin. Only applies if Mfr_pg_operation=10b or 11b. 0: Input undervoltage not mapped to PG pin.
b[7]	Mfr_pg_fault_sel_ton_max	1: TON_MAX_FAULT sequencing fault mapped to PG pin. Only applies if Mfr_pg_operation=10b or 11b. 0: TON_MAX_FAULT sequencing fault not mapped to PG pin.
b[6]	Mfr_pg_fault_sel_vout_en	1: Inverted output enable mapped to PG pin. 0: Inverted output enable not mapped to PG pin.
b[5]	Reserved	Reserved, always returns 0
b[4:2]	Mfr_pg_ov_uv_deglitch	Additional deglitch value for assertion and de-assertion of overvoltage and undervoltage signals to PG: 111b: 100ms 110b: 50ms 101b: 20ms 100b: 10ms 011b: 5ms 010b: 1ms 001b: 200µs 000b: There is no additional deglitch delay applied to the signal
b[1:0]	Mfr_pg_operation	11b: Active Hi-Z propagation of faults according to Mfr_pg_fault_sel 10b: Active low propagation of faults according to Mfr_pg_fault_sel 01b: Reserved 00b: Force PG pin to value set by Mfr_pg_gpo_force in MFR_PG_GPO register

PMBus COMMAND DESCRIPTION

MFR_PG_GPO

The paged MFR_PG_GPO register defines the output logic state of the PG pins if Mfr_pg_operation equals 2'b00. This register is write protected during Level 1 protection only.

MFR_PG_GPO Data Contents

BIT(S)	SYMBOL	OPERATION
b[7:1]	Reserved	Reserved, always returns 0
b[0]	Mfr_pg_gpo_force	1: Force PG Hi-Z 0: Force PG Low

MFR_PWRGD_EN

This command register controls the mapping of the watchdog and channel power good status to the PWRGD pin.

MFR_PWRGD_EN Data Contents

BIT(S)	SYMBOL	OPERATION
b[15:9]	Reserved	Read only, always returns 0s.
b[8]	Mfr_pwrzd_en_wdog	Watchdog. 1 = Watchdog timer not-expired status is ANDed with PWRGD status for any similarly enabled channels to determine when the PWRGD pin gets asserted. 0 = Watchdog timer does not affect the PWRGD pin.
b[7:2]	Reserved	Always returns 000000b.
b[1]	Mfr_pwrzd_en_chan1	Channel 1. 1 = PWRGD status for this channel is ANDed with PWRGD status for any similarly enabled channels to determine when the PWRGD pin gets asserted. 0 = PWRGD status for this channel does not affect the PWRGD pin.
b[0]	Mfr_pwrzd_en_chan0	Channel 0. 1 = PWRGD status for this channel is ANDed with PWRGD status for any similarly enabled channels to determine when the PWRGD pin gets asserted. 0 = PWRGD status for this channel does not affect the PWRGD pin.

MFR_POWERGOOD_ASSERTION_DELAY

This command register allows the user to program the delay from when the internal power-good signal becomes valid until the PWRGD pin output is asserted. This delay is counted using SHARE_CLK if available, otherwise the internal oscillator is used. This delay is internally limited to 13.1 seconds, and rounded to the nearest 200µs. The read value of this command always returns what was last written and does not reflect internal limiting.

The PWRGD pin de-assertion delay and threshold source is controlled by Mfr_config_all_pwrzd_off_uses_uv. Systems that require a fast PWRGD pin de-assertion should set Mfr_config_all_pwrzd_off_uses_uv = 1. This uses the VOUT_UV_FAULT_LIMIT and the high speed comparator to de-assert the PWRGD pin. Systems that require a separate power good off threshold should set Mfr_config_all_pwrzd_off_uses_uv = 0. This uses the slower ADC polling loop and POWER_GOOD_OFF to de-assert the PWRGD pin.

PMBus COMMAND DESCRIPTION

Watchdog Operation

A non-zero write to the MFR_WATCHDOG_T register will reset the watchdog timer. Low-to-high transitions on the WDI/RESETB pin also reset the watchdog timer. If the timer expires, ALERTB is asserted and the PWRGD output is optionally de-asserted and then reasserted after MFR_PWRGD_ASSERTION_DELAY ms. Writing 0 to either the MFR_WATCH_DOG_T or MFR_WATCHDOG_T_FIRST registers will disable the timer.

MFR_WATCHDOG_T_FIRST and MFR_WATCHDOG_T

The MFR_WATCHDOG_T_FIRST register allows the user to program the duration of the first watchdog timer interval following assertion of the PWRGD pin, assuming the PWRGD pin reflects the status of the watchdog timer. If assertion of PWRGD is not conditioned by the watchdog timer's status, then MFR_WATCHDOG_T_FIRST applies to the first timing interval after the timer is enabled. Writing a value of 0ms to the MFR_WATCHDOG_T_FIRST register disables the watchdog timer. This delay is internally limited to 65 seconds and rounded to the nearest 1ms.

The MFR_WATCHDOG_T register allows the user to program watchdog timer intervals subsequent to the MFR_WATCHDOG_T_FIRST timing interval. Writing a value of 0ms to the MFR_WATCHDOG_T register disables the watchdog timer. This delay is internally limited to 655ms and rounded to the nearest 10 μ s.

Both timers operate on an internal clock independent of SHARE_CLK. The read value of both commands always returns what was last written and does not reflect internal limiting.

FAULT RESPONSES

COMMAND NAME	CMD CODE	DESCRIPTION	TYPE	PAGED	FORMAT	UNITS	EEPROM	DEFAULT VALUE	REF PAGE
VOUT_OV_FAULT_RESPONSE	0x41	Action to be taken by the device when an output overvoltage fault is detected.	R/W Byte	Y	Reg		Y	0x80	64
VOUT_UV_FAULT_RESPONSE	0x45	Action to be taken by the device when an output undervoltage fault is detected.	R/W Byte	Y	Reg		Y	0x7F	64
OT_FAULT_RESPONSE	0x50	Action to be taken by the device when an overtemperature fault is detected on the external temperature sensor.	R/W Byte	Y	Reg		Y	0xB8	65
UT_FAULT_RESPONSE	0x54	Action to be taken by the device when an undertemperature fault is detected on the external temperature sensor.	R/W Byte	Y	Reg		Y	0xB8	65
VIN_OV_FAULT_RESPONSE	0x56	Action to be taken by the device when an input overvoltage fault is detected.	R/W Byte	N	Reg		Y	0x80	65
VIN_UV_FAULT_RESPONSE	0x5A	Action to be taken by the device when an input undervoltage fault is detected.	R/W Byte	N	Reg		Y	0x00	65
TON_MAX_FAULT_RESPONSE	0x63	Action to be taken by the device when a TON_MAX_FAULT event is detected.	R/W Byte	Y	Reg		Y	0xB8	65
MFR_RETRY_DELAY	0xDB	Retry interval during FAULT retry mode.	R/W Word	N	L11	ms	Y	200 0xF320	66
MFR_RETRY_COUNT	0xF7	Retry count for all faulted off conditions that enable retry.	R/W Byte	N	Reg		Y	0x00	52

PMBus COMMAND DESCRIPTION

Clearing Latched Faults

Latched faults are reset by toggling the CONTROL pin, using the OPERATION command, or removing and reapplying the bias voltage to the V_{IN_SNS} pin. All fault and warning conditions result in the ALERTB pin being asserted low and the corresponding bits being set in the status registers. The CLEAR_FAULTS command resets the contents of the status registers and de-asserts the ALERTB output. The CLEAR_FAULTS does not clear a faulted off state nor allow a channel to turn back on.

VOUT_OV_FAULT_RESPONSE and VOUT_UV_FAULT_RESPONSE

The fault response documented here is for voltages that are measured by the high speed supervisor. These voltages are measured over a short period of time and may require a deglitch period. Note that in addition to the response described by these commands, the LTC2972 will also:

- Set the appropriate bit(s) in the STATUS_BYTE.
- Set the appropriate bit(s) in the STATUS_WORD.
- Set the appropriate bit in the corresponding STATUS_VOUT register, and
- Notify the host by pulling the ALERTB pin low.

VOUT_OV_FAULT_RESPONSE and VOUT_UV_FAULT_RESPONSE Data Contents

BIT(S)	SYMBOL	OPERATION
b[7:6]	Vout_ov_fault_response_action, Vout_uv_fault_response_action	Response action: 00b: The unit continues operation without interruption. 01b: The unit continues operating for the delay time specified by bits[2:0] in increments of t_{S_VS} . See Electrical Characteristics Table. If the fault is still present at the end of the delay time, the unit shuts down immediately or sequences off after TOFF_DELAY (See Mfr_config_track_en). After shutting down, the device responds according to the retry settings in bits [5:3]. 10b-11b: The unit shuts down immediately or sequences off after TOFF_DELAY (See Mfr_config_track_en). After shutting down, the device responds according to the retry settings in bits [5:3].
b[5:3]	Vout_ov_fault_response_retry, Vout_uv_fault_response_retry	Response retry behavior: 000b: A zero value for the retry setting means that the unit does not attempt to restart. The output remains disabled until the fault is cleared. 001b-111b: The PMBus device attempts to restart the number of times specified by the global Mfr_retry_count[2:0] until it is commanded OFF (by the CONTROL pin or OPERATION command or both), bias power is removed, or another fault condition causes the unit to shut down. Changing the value might not take effect until the next off-then-on sequence on that channel.
b[2:0]	Vout_ov_fault_response_delay, Vout_uv_fault_response_delay	This sample count determines the amount of time a unit is to ignore a fault after it is first detected. Use this delay to deglitch fast faults. 000b: There is no additional deglitch delay applied to fault detection. 001b-111b: The fault is deglitched for deglitch period of b[2:0] samples at a sampling period of t_{S_VS} (12.2 μ s typical).

PMBus COMMAND DESCRIPTION

OT_FAULT_RESPONSE, UT_FAULT_RESPONSE, VIN_OV_FAULT_RESPONSE and VIN_UV_FAULT_RESPONSE

The fault response documented here is for values that are measured by the ADC. Note that in addition to the response described by these commands, the LTC2972 will also:

- Set the appropriate bit(s) in the STATUS_BYTE.
- Set the appropriate bit(s) in the STATUS_WORD.
- Set the appropriate bit in the corresponding STATUS_VIN or STATUS_TEMPERATURE register, and
- Notify the host by pulling the ALERTB pin low.

OT_FAULT_RESPONSE, UT_FAULT_RESPONSE, VIN_OV_FAULT_RESPONSE, VIN_UV_FAULT_RESPONSE Data Contents

BIT(S)	SYMBOL	OPERATION
b[7:6]	Ot_fault_response_action, Ut_fault_response_action, Vin_ov_fault_response_action, Vin_uv_fault_response_action	Response action: 00b: The unit continues operation without interruption. 01b-11b: The unit shuts down immediately or sequences off after TOFF_DELAY (See Mfr_config_track_enr). After shutting down, the device responds according to the retry settings in bits [5:3].
b[5:3]	Ot_fault_response_retry, Ut_fault_response_retry, Vin_ov_fault_response_retry, Vin_uv_fault_response_retry	Response retry behavior: 000b: A zero value for the retry setting means that the unit does not attempt to restart. The output remains disabled until the fault is cleared. 001b-111b: The PMBus device attempts to restart the number of times specified by the global Mfr_retry_count[2:0] until it is commanded OFF (by the CONTROL pin or OPERATION command or both), bias power is removed, or another fault condition causes the unit to shut down. Changing the value might not take effect until the next off-then-on sequence on that channel.
b[2:0]	Ot_fault_response_delay, Ut_fault_response_delay, Vin_ov_fault_response_delay, Vin_uv_fault_response_delay	Hard coded to 000b: There is no additional deglitch delay applied to fault detection.

TON_MAX_FAULT_RESPONSE

This command defines the LTC2972 response to a TON_MAX_FAULT. It may be used to protect against a short-circuited output at startup. After startup use VOUT_UV_FAULT_RESPONSE to protect against a short-circuited output.

The device also:

- Sets the HIGH_BYTE bit in the STATUS_BYTE,
- Sets the V_{OUT} bit in the STATUS_WORD,
- Sets the TON_MAX_FAULT bit in the STATUS_VOUT register, and
- Notifies the host by asserting ALERTB.

PMBus COMMAND DESCRIPTION

TON_MAX_FAULT_RESPONSE Data Contents

BIT(S)	SYMBOL	OPERATION
b[7:6]	Ton_max_fault_response_action	Response action: 00b: The unit continues operation without interruption. 01b-11b: The unit shuts down immediately or sequences off after TOFF_DELAY (See Mfr_config_track_en). After shutting down, the device responds according to the retry settings in bits [5:3].
b[5:3]	Ton_max_fault_response_retry	Response retry behavior: 000b: A zero value for the retry setting means that the unit does not attempt to restart. The output remains disabled until the fault is cleared. 001b-111b: The PMBus device attempts to restart the number of times specified by the global Mfr_retry_count[2:0] until it is commanded OFF (by the CONTROL pin or OPERATION command or both), bias power is removed, or another fault condition causes the unit to shut down. Changing the value might not take effect until the next off-then-on sequence on that channel.
b[2:0]	Ton_max_fault_response_delay	Hard coded to 000b: There is no additional deglitch delay applied to fault detection.

MFR_RETRY_DELAY

This command determines the retry interval when the LTC2972 is in retry mode in response to a fault condition. This delay is counted using SHARE_CLK only. This delay is internally limited to 13.1 seconds, and rounded to the nearest 200µs. The read value of this command always returns what was last written and does not reflect internal limiting.

MR_RETRY_COUNT

The MFR_RETRY_COUNT is a global command that sets the number of retries attempted when any channel faults off with its fault response retry field set to a non zero value.

In the event of multiple or recurring retry faults on the same channel the total number of retries equals MFR_RETRY_COUNT. If a channel has not been faulted off for at least 16 seconds, its retry counter is cleared. Toggling a channel's CONTROL pin off then on or issuing OPERATION off then on commands will synchronously clear the retry count.

MFR_RETRY_COUNT Data Contents

BIT(S)	SYMBOL	OPERATION
b[7:3]	Reserved	Always returns zero.
b[2:0]	Mfr_retry_count [2:0]	0: No retries: 1-6: Number of retries. 7: Infinite retries. Changing the value might not take effect until the next off-then-on sequence on that channel.

PMBus COMMAND DESCRIPTION

SHARED EXTERNAL FAULTS

COMMAND NAME	CMD CODE	DESCRIPTION	TYPE	PAGED	FORMAT	UNITS	EEPROM	DEFAULT VALUE	REF PAGE
MFR_FAULTB0_PROPAGATE	0xD2	Configuration that determines if a channels faulted off state is propagated to the FAULTB0 pin.	R/W Byte	Y	Reg		Y	0x00	67
MFR_FAULTB1_PROPAGATE	0xD3	Configuration that determines if a channels faulted off state is propagated to the FAULTB1 pin.	R/W Byte	Y	Reg		Y	0x00	67
MFR_FAULTB0_RESPONSE	0xD5	Action to be taken by the device when the FAULTB0 pin is asserted low.	R/W Byte	N	Reg		Y	0x00	67
MFR_FAULTB1_RESPONSE	0xD6	Action to be taken by the device when the FAULTB1 pin is asserted low.	R/W Byte	N	Reg		Y	0x00	67

MFR_FAULTB0_PROPAGATE and MFR_FAULTB1_PROPAGATE

These manufacturer specific commands enable channels that have faulted off to propagate that state to the appropriate fault pin. MFR_FAULTB0_PROPAGATE allows any channel's faulted off state to propagate to the FAULTB0 pin. MFR_FAULTB1_PROPAGATE allows any channel's faulted off state to propagate to the FAULTB1 pin.

Note that pulling a fault pin low will have no effect for channels that have MFR_FAULTBn_RESPONSE set to 0. The channel continues operation without interruption. This fault response is called Ignore (0x0) in LTpowerPlay.

MFR_FAULT0_PROPAGATE Data Contents

BIT(S)	SYMBOL	OPERATION
b[7:1]	Reserved	Don't care. Always returns 0.
b[0]	Mfr_faultb0_propagate	Enable fault propagation. 0: Channel's faulted off state does not assert FAULTB0 low. 1: Channel's faulted off state asserts FAULTB0 low.

MFR_FAULT1_PROPAGATE Data Contents

BIT(S)	SYMBOL	OPERATION
b[7:1]	Reserved	Don't care. Always returns 0.
b[0]	Mfr_faultb1_propagate	Enable fault propagation. 0: Channel's faulted off state does not assert FAULTB1 low. 1: Channel's faulted off state asserts FAULTB1 low.

MFR_FAULTB0_RESPONSE and MFR_FAULTB1_RESPONSE

These manufacturer specific commands share the same format and specify the response to assertions of the FAULTB pins. MFR_FAULTB0_RESPONSE determines which channels shut off when the FAULTB0 pin is asserted low and MFR_FAULTB1_RESPONSE determines which channels shut off when the FAULTB1 pin is asserted low. When a channel shuts off in response to a FAULTBn pin, the ALERTB pin is asserted low and the appropriate bit is set in the STATUS_MFR_SPECIFIC register. For a graphical explanation, see the switches on the left hand side of Figure 31: Channel Fault Management Block Diagram.

Faults will not propagate for channels that have MFR_FAULTBn_RESPONSE set to 0: The channel continues operation without interruption. Note that this fault response is called No Action in LTpowerPlay.

PMBus COMMAND DESCRIPTION

MFR_FAULTB0_RESPONSE and MFR_FAULTB1_RESPONSE Data Contents

BIT(S)	SYMBOL	OPERATION
b[7:2]	Reserved	Read only, always returns 000000b.
b[1]	Mfr_faultb0_response_chan1, Mfr_faultb1_response_chan1	Channel 1 response. 0: The channel continues operation without interruption 1: The channel shuts down if the corresponding FAULTB pin is still asserted after 10 μ s. When the FAULTB pin subsequently de-asserts, the channel turns back on, honoring TON_DELAY and TON_RISE settings.
b[0]	Mfr_faultb0_response_chan0, Mfr_faultb1_response_chan0	Channel 0 response. 0: The channel continues operation without interruption 1: The channel shuts down if the corresponding FAULTB pin is still asserted after 10 μ s. When the FAULTB pin subsequently de-asserts, the channel turns back on, honoring TON_DELAY and TON_RISE settings.

FAULT WARNING AND STATUS

COMMAND NAME	CMD CODE	DESCRIPTION	TYPE	PAGED	FORMAT	UNITS	EEPROM	DEFAULT VALUE	REF PAGE
CLEAR_FAULTS	0x03	Clear any fault bits that have been set.	Send Byte	Y				NA	68
STATUS_BYTE	0x78	One byte summary of the unit's fault condition.	R Byte	Y	Reg			NA	69
STATUS_WORD	0x79	Two byte summary of the unit's fault condition.	R Word	Y	Reg			NA	69
STATUS_VOUT	0x7A	Output voltage fault and warning status.	R Byte	Y	Reg			NA	70
STATUS_IOUT	0x7B	Output current fault and warning status.	R Byte	Y	Reg			NA	70
STATUS_INPUT	0x7C	Input supply fault and warning status.	R Byte	N	Reg			NA	70
STATUS_TEMPERATURE	0x7D	External temperature fault and warning status for READ_TEMPERATURE_1.	R Byte	Y	Reg			NA	71
STATUS_CML	0x7E	Communication and memory fault and warning status.	R Byte	N	Reg			NA	71
STATUS_MFR_SPECIFIC	0x80	Manufacturer specific fault and state information.	R Byte	Y	Reg			NA	72
MFR_PADS	0xE5	Current state of selected digital I/O pads.	R Word	N	Reg			NA	72
MFR_COMMON	0xEF	Manufacturer status bits that are common across multiple ADI chips.	R Byte	N	Reg			NA	73
MFR_FIRST_FAULT	0xB6	First fault information	R Word	N	Reg				74
MFR_STATUS_2	0xB7	Manufacturer Specific Status	R Word	Y	Reg			NA	73

CLEAR_FAULTS

The CLEAR_FAULTS command is used to clear status bits that have been set. This command clears all fault and warning bits in all unpagged status registers, and pagged status registers selected by the current PAGE setting. At the same time, the device negates (clears, releases) its contribution to ALERTB.

The CLEAR_FAULTS command does not cause a unit that has latched off for a fault condition to restart. See Clearing Latched Faults for more information.

If the fault is present after the fault is cleared, the fault status bit will be set again and the host notified by the usual means.

Note: this command responds to the global page command. (PAGE=0xFF)

PMBus COMMAND DESCRIPTION

STATUS_BYTE

The STATUS_BYTE command returns the summary of the most critical faults or warnings which have occurred, as shown in the following table. STATUS_BYTE is a subset of STATUS_WORD and duplicates the same information.

STATUS_BYTE Data Contents

BIT(S)	SYMBOL	OPERATION
b[7]	Status_byte_busy	Same as Status_word_busy.
b[6]	Status_byte_off	Same as Status_word_off.
b[5]	Status_byte_vout_ov	Same as Status_word_vout_ov.
b[4]	Status_byte_iout_oc	Not supported. Always returns 0.
b[3]	Status_byte_vin_uv	Same as Status_word_vin_uv.
b[2]	Status_byte_temp	Same as Status_word_temp.
b[1]	Status_byte_cml	Same as Status_word_cml.
b[0]	Status_byte_high_byte	Same as Status_word_high_byte.

STATUS_WORD

The STATUS_WORD command returns two bytes of information with a summary of the unit's fault condition. Based on the information in these bytes, the host can get more information by reading the appropriate detailed status register.

The low byte of the STATUS_WORD is the same register as the STATUS_BYTE command.

STATUS_WORD Data Contents

BIT(S)	SYMBOL	OPERATION
b[15]	Status_word_vout	An output voltage fault or warning has occurred. See STATUS_VOUT.
b[14]	Status_word_iout	An output current warning has occurred. See STATUS_IOUT.
b[13]	Status_word_input	An input voltage fault or warning has occurred. See STATUS_INPUT.
b[12]	Status_word_mfr	A manufacturer specific fault has occurred. See STATUS_MFR_SPECIFIC.
b[11]	Status_word_power_not_good	The PWRGD pin, if enabled, is negated. Power is not good.
b[10]	Status_word_fans	Not supported. Always returns 0.
b[9]	Status_word_other	Not supported. Always returns 0.
b[8]	Status_word_unknown	Not supported. Always returns 0.
b[7]	Status_word_busy	Device busy when PMBus command received. See OPERATION: Processing Commands.
b[6]	Status_word_off	This bit is asserted if the unit is not providing power to the output, regardless of the reason, including simply not being enabled. The off-bit is clear if unit is allowed to provide power to the output.
b[5]	Status_word_vout_ov	An output overvoltage fault has occurred.
b[4]	Status_word_iout_oc	Not supported. Always returns 0.
b[3]	Status_word_vin_uv	A V_{IN} undervoltage fault has occurred.
b[2]	Status_word_temp	A temperature fault or warning has occurred. See STATUS_TEMPERATURE.
b[1]	Status_word_cml	A communication, memory or logic fault has occurred. See STATUS_CML.
b[0]	Status_word_high_byte	A fault/warning not listed in b[7:1] has occurred or Status_word_power_not_good = 1.

PMBus COMMAND DESCRIPTION

STATUS_VOUT

The STATUS_VOUT command returns the summary of the output voltage faults or warnings which have occurred, as shown in the following table:

STATUS_VOUT Data Contents

BIT(S)	SYMBOL	OPERATION
b[7]	Status_vout_ov_fault	Overvoltage fault.
b[6]	Status_vout_ov_warn	Overvoltage warning.
b[5]	Status_vout_uv_warn	Undervoltage warning.
b[4]	Status_vout_uv_fault	Undervoltage fault.
b[3]	Status_vout_max_warn	VOUT_MAX warning. An attempt has been made to set the output voltage to a value higher than allowed by the VOUT_MAX command.
b[2]	Status_vout_ton_max_fault	TON_MAX_FAULT sequencing fault.
b[1]	Status_vout_toff_max_warn	Not supported. Always returns 0.
b[0]	Status_vout_tracking_error	Not supported. Always returns 0.

STATUS_IOUT

The STATUS_IOUT command returns the summary of the output current faults or warnings which have occurred, as shown in the following table:

STATUS_IOUT Data Contents

BIT(S)	SYMBOL	OPERATION
b[7]	Status_iout_oc_fault	Not supported. Always returns 0.
b[6]	Status_iout_oc_uv_fault	Not supported. Always returns 0.
b[5]	Status_iout_oc_warn	Overcurrent warning.
b[4]	Status_iout_uc_fault	Not supported. Always returns 0.
b[3]	Status_curr_share_fault	Not supported. Always returns 0.
b[2]	Status_pout_power_limiting	Not supported. Always returns 0.
b[1]	Status_pout_overpower_fault	Not supported. Always returns 0.
b[0]	Status_pout_overpower_warn	Not supported. Always returns 0.

STATUS_INPUT

The STATUS_INPUT command returns the summary of the V_{IN} faults or warnings which have occurred, as shown in the following table:

STATUS_INPUT Data Contents

BIT(S)	SYMBOL	OPERATION
b[7]	Status_input_ov_fault	V_{IN} overvoltage fault.
b[6]	Status_input_ov_warn	V_{IN} overvoltage warning.
b[5]	Status_input_uv_warn	V_{IN} undervoltage warning.
b[4]	Status_input_uv_fault	V_{IN} undervoltage fault.
b[3]	Status_input_off	Unit is off for insufficient input voltage.
b[2]	IIN overcurrent fault	Not supported. Always returns 0.
b[1]	IIN overcurrent warn	Not supported. Always returns 0.
b[0]	PIN overpower warn	Not supported. Always returns 0.

PMBus COMMAND DESCRIPTION

STATUS_TEMPERATURE

The STATUS_TEMPERATURE command returns the summary of the temperature faults or warnings which have occurred, as shown in the following table. Note that this information is paged and refers to the temperature of the associated external diode.

STATUS_TEMPERATURE Data Contents

BIT(S)	SYMBOL	OPERATION
b[7]	Status_temperature_ot_fault	Overtemperature fault.
b[6]	Status_temperature_ot_warn	Overtemperature warning.
b[5]	Status_temperature_ut_warn	Undertemperature warning.
b[4]	Status_temperature_ut_fault	Undertemperature fault.
b[3]	Reserved	Reserved. Always returns 0.
b[2]	Reserved	Reserved. Always returns 0.
b[1]	Reserved	Reserved. Always returns 0.
b[0]	Reserved	Reserved. Always returns 0.

STATUS_CML

The STATUS_CML command returns the summary of the communication, memory and logic faults or warnings which have occurred, as shown in the following table:

STATUS_CML Data Contents

BIT(S)	SYMBOL	OPERATION
b[7]	Status_cml_cmd_fault	1 = An illegal or unsupported command fault has occurred. 0 = No fault has occurred.
b[6]	Status_cml_data_fault	1 = Illegal or unsupported data received. 0 = No fault has occurred.
b[5]	Status_cml_pec_fault	1 = A packet error check fault has occurred. Note: PEC checking is always active in the LTC2972. Any extra byte received before a STOP will set Status_cml_pec_fault unless the extra byte is a matching PEC byte. 0 = No fault has occurred.
b[4]	Status_cml_memory_fault	1 = A fault has occurred in the EEPROM. 0 = No fault has occurred.
b[3]	Status_cml_processor_fault	Not supported, always returns 0.
b[2]	Reserved	Reserved, always returns 0.
b[1]	Status_cml_pmbus_fault	1 = A communication fault other than ones listed in this table has occurred. This is a catch all category for illegally formed I ² C/SMBus commands (Example: An address byte with read =1 received immediately after a START). 0 = No fault has occurred.
b[0]	Status_cml_unknown_fault	Not supported, always returns 0.

PMBus COMMAND DESCRIPTION

STATUS_MFR_SPECIFIC

The STATUS_MFR_SPECIFIC command returns manufacturer specific status flags. Bits marked CHANNEL = All are not paged. Bits marked STICKY = Yes stay set until a CLEAR_FAULTS is issued or the channel is commanded on by the user. Bits marked ALERT = Yes pull ALERTB low when the bit is set. Bits marked OFF = Yes indicate that the event can be configured elsewhere to turn the channel off.

STATUS_MFR_SPECIFIC Data Contents

BIT(S)	SYMBOL	OPERATION	CHANNEL	STICKY	ALERT	OFF
b[7]	Status_mfr_discharge	1 = A V_{OUT} discharge fault occurred while attempting to enter the ON state. 0 = No V_{OUT} discharge fault has occurred.	Current Page	Yes	Yes	Yes
b[6]	Status_mfr_fault1_in	This channel attempted to turn on while the FAULTB1 pin was asserted low, or this channel has shut down at least once in response to a FAULTB1 pin asserting low since the last CONTROL pin toggle, OPERATION command ON/OFF cycle or CLEAR_FAULTS command.	Current Page	Yes	Yes	Yes
b[5]	Status_mfr_fault0_in	This channel attempted to turn on while the FAULTB0 pin was asserted low, or this channel has shut down at least once in response to a FAULTB0 pin asserting low since the last CONTROL pin toggle, OPERATION command ON/OFF cycle or CLEAR_FAULTS command.	Current Page	Yes	Yes	Yes
b[4]	Status_mfr_servo_target_reached	Servo target has been reached.	Current Page	No	No	No
b[3]	Status_mfr_dac_connected	DAC is connected and driving V_{DAC} pin.	Current Page	No	No	No
b[2]	Status_mfr_dac_saturated	A previous servo operation terminated with maximum or minimum DAC value.	Current Page	Yes	No	No
b[1]	Status_mfr_auxfaultb_faulted_off	AUXFAULTB has been de-asserted due to a V_{OUT} or I_{OUT} fault.	All	No	No	No
b[0]	Status_mfr_watchdog_fault	1 = A watchdog fault has occurred. 0 = No watchdog fault has occurred.	All	Yes	Yes	No

MFR_PADS

The MFR_PADS command provides read-only access of digital pads (pins). The input values are before any deglitching logic.

MFR_PADS Data Contents

BIT(S)	SYMBOL	OPERATION
b[15]	Mfr_pads_pwrpd_drive	0 = PWRGD pad is being driven low by this chip. 1 = PWRGD pad is not being driven low by this chip.
b[14]	Mfr_pads_alertb_drive	0 = ALERTB pad is being driven low by this chip. 1 = ALERTB pad is not being driven low by this chip.
b[13:12]	Mfr_pads_faultb_drive[1:0]	bit[1] used for FAULTB0 pad, bit[0] used for FAULTB1 pad as follows: 0 = FAULTB pad is being driven low by this chip. 1 = FAULTB pad is not being driven low by this chip.
b[11:10]	Mfr_pads_pg_drive[1:0]	bit[1] used for PG1 pad, bit[0] used for PG0 pad as follows: 0 = PG_n pad is being driven low by this chip 1 = PG_n pad is not being driven low by this chip
b[9:8]	Mfr_pads_asel1[1:0]	11: Logic high detected on ASEL1 input pad. 10: ASEL1 input pad is floating. 01: Reserved. 00: Logic low detected on ASEL1 input pad.

PMBus COMMAND DESCRIPTION

MFR_PADS Data Contents

BIT(S)	SYMBOL	OPERATION
b[7:6]	Mfr_pads_asel0[1:0]	11: Logic high detected on ASELO input pad. 10: ASELO input pad is floating. 01: Reserved. 00: Logic low detected on ASELO input pad.
b[5]	Mfr_pads_control1	1: Logic high detected on CONTROL1 pad. 0: Logic low detected on CONTROL1 pad.
b[4]	Mfr_pads_control0	1: Logic high detected on CONTROL0 pad. 0: Logic low detected on CONTROL0 pad.
b[3:2]	Mfr_pads_faultb[1:0]	bit[1] used for FAULTB0 pad, bit[0] used for FAULTB1 pad as follows: 1: Logic high detected on FAULTB pad. 0: Logic low detected on FAULTB pad.
b[1]	Mfr_pads_pg1	1: Logic high detected on PG1 pad. 0: Logic low detected on PG1 pad.
b[0]	Mfr_pads_pg0	1: Logic high detected on PG0 pad. 0: Logic low detected on PG0 pad.

MFR_COMMON

This command returns status information for the alert, device busy, share-clock pin (SHARE_CLK) and the write-protect pin (WP).

This is the only command that may still be read when the LTC2972 is busy processing an EEPROM or other command. It may be polled by the host to determine when the LTC2972 is available to process a PMBus command. A busy device will always acknowledge its address but will NACK the command byte and set Status_byte_busy and Status_word_busy when it receives a command that it cannot immediately process. ALERTB will be asserted low in this case.

MFR_COMMON Data Contents

BIT(S)	SYMBOL	OPERATION
b[7]	Mfr_common_alertb	Returns alert status. 1: ALERTB is de-asserted high. 0: ALERTB is asserted low.
b[6]	Mfr_common_busyb	Returns device busy status. 1: The device is available to process PMBus commands. 0: The device is busy and will NACK PMBus commands.
b[5:2]	Reserved	Read only, always returns 1s.
b[1]	Mfr_common_share_clk	Returns the status of the share-clock pin. 1: Share-clock pin is being held low. 0: Share-clock pin is active.
b[0]	Mfr_common_write_protect	Returns the status of the write-protect pin. 1: Write-protect pin is high. 0: Write-protect pin is low.

PMBus COMMAND DESCRIPTION

MFR_STATUS_2

This command returns additional manufacturer specific fault and state information. Bits marked Sticky = Yes are set by the appropriate event and not cleared until the user issues a CLEAR_FAULTS command or turns the channel back on. Bits marked ALERT = YES assert ALERTB low when they are set. Bits marked Channel = All are not paged.

MFR_STATUS_2 Data Contents

BIT(S)	SYMBOL	OPERATION	STICKY	ALERT	CHANNEL
b[15:3]	Mfr_status_2_reserved	Read only, always returns 0.			
b[2]	Mfr_status_2_shortcycle_fault	1: This channel was commanded on by user before it finished sequencing off. 0: No short cycle fault has occurred on this channel.	Yes	Yes	Current Page
b[1]	Mfr_status_2_vinen_drive	1: AUXFAULTB pad is being driven low by this chip. 0: AUXFAULTB pad is not being driven low by this chip.	No	No	All
b[0]	Mfr_status_2_vin_caused_off	1: This channel was turned off due to VIN_SNS dropping below the VIN_OFF threshold. 0: VIN_SNS has not caused this channel to turn off.	Yes	No	Current Page

MFR_FIRST_FAULT

The MFR_FIRST_FAULT register contains a value that indicates the first observed fault by the LTC2972 that caused a channel to fault off. This value is stored in the fault log and is cleared to 0x0000 by sending either the CLEAR_FAULTS command or cycling a channel off then on. This register will capture the first observed fault regardless of whether fault logging is enabled. The LTC2972 will store an additional byte into the fault log, FirstFaultTime, that is a snapshot copy of the least significant 8 bits of the shared-timer value at the time the first fault was detected. Using the FirstFaultTime value a user can pinpoint a first fault occurrence to within 200µs of all LTC2972 devices with connected SHARE_CLK pins. The FirstFaultTime value will be reset whenever the MFR_FIRST_FAULT is cleared.

MFR_FIRST_FAULT Data Contents

BIT(S)	SYMBOL	OPERATION
b[15:12]	Mfr_first_fault_page	The page of the first observed fault: 0xF: Global 0x1: Channel 1 0x0: Channel 0 All other values reserved
b[11:8]	Mfr_first_fault_bit_num	Bit number of the status register indicated by Mfr_first_fault_cmd that contains the first observed fault condition
b[7:0]	Mfr_first_fault_cmd	The PMBus command of the status register that contains the first observed fault condition: 0x80: STATUS_MFR_SPECIFIC 0x7D: STATUS_TEMPERATURE 0x7C: STATUS_INPUT 0x7A: STATUS_VOUT 0x00: None All other values reserved

PMBus COMMAND DESCRIPTION

TELEMETRY

COMMAND NAME	CMD CODE	DESCRIPTION	TYPE	PAGED	FORMAT	UNITS	EEPROM	DEFAULT VALUE	REF PAGE
READ_VIN	0x88	Input supply voltage.	R Word	N	L11	V		NA	75
READ_IIN	0x89	DC/DC converter input current.	R Word	Y	L11	A		NA	75
READ_PIN	0x97	DC/DC converter input power.	R Word	Y	L11	W		NA	75
READ_VOUT	0x8B	DC/DC converter output voltage.	R Word	Y	L16	V		NA	75
READ_IOUT	0x8C	DC/DC converter output current.	R Word	Y	L11	A		NA	76
READ_TEMPERATURE_1	0x8D	External diode junction temperature. This is the value used for all temperature related processing, including IOUT_CAL_GAIN.	R Word	Y	L11	°C		NA	76
READ_TEMPERATURE_2	0x8E	Internal junction temperature.	R Word	N	L11	°C		NA	76
READ_POUT	0x96	DC/DC converter output power.	R Word	Y	L11	W		NA	77
MFR_READ_IOUT	0xBB	Alternate data format for READ_IOUT. One LSB = 2.5mA.	R Word	Y	CF	2.5mA		NA	77
MFR_IIN_PEAK	0xC4	Maximum measured value of READ_IIN	R Word	Y	L11	A		NA	76
MFR_IIN_MIN	0xC5	Minimum measured value of READ_IIN.	R Word	Y	L11	A		NA	76
MFR_PIN_PEAK	0xC6	Maximum measured value of READ_PIN.	R Word	Y	L11	W		NA	76
MFR_PIN_MIN	0xC7	Minimum measured value of READ_PIN.	R Word	Y	L11	W		NA	76
MFR_IOUT_SENSE_VOLTAGE	0xFA	Absolute value of VISENSEP – VISENSEM. One LSB = 3.05µV or 91.5µV.	R Word	Y	CF	µV		NA	78
MFR_VIN_PEAK	0xDE	Maximum measured value of READ_VIN.	R Word	N	L11	V		NA	78
MFR_VOUT_PEAK	0xDD	Maximum measured value of READ_VOUT.	R Word	Y	L16	V		NA	78
MFR_IOUT_PEAK	0xD7	Maximum measured value of READ_IOUT.	R Word	Y	L11	A		NA	78
MFR_TEMPERATURE_1_PEAK	0xDF	Maximum measured value of READ_TEMPERATURE_1.	R Word	Y	L11	°C		NA	78
MFR_VIN_MIN	0xFC	Minimum measured value of READ_VIN.	R Word	N	L11	V		NA	78
MFR_VOUT_MIN	0xFB	Minimum measured value of READ_VOUT.	R Word	Y	L16	V		NA	78
MFR_IOUT_MIN	0xD8	Minimum measured value of READ_IOUT.	R Word	Y	L11	A		NA	79
MFR_TEMPERATURE_1_MIN	0xFD	Minimum measured value of READ_TEMPERATURE_1.	R Word	Y	L11	°C		NA	79

READ_VIN

This command returns the most recent ADC measured value of the input voltage at the V_{IN_SNS} pin.

READ_IIN

This command returns the most recent ADC measured value of the input current derived from the voltage difference between the IIN_SNSP and IIN_SNSM pins. The READ_IIN value reported is automatically corrected to account for the range selected by Mfr_ein_config_iin_range[1:0].

READ_PIN

This command returns the most recent ADC measured value of the input power in watts. This is the product of READ_IIN and READ_VIN.

READ_VOUT

This command returns the most recent ADC measured value of the channel's output voltage.

PMBus COMMAND DESCRIPTION

READ_IOUT

This command returns the most recent ADC measured value of the channel's output current.

MFR_IIN_PEAK

This command returns the maximum ADC measured value of the input current. This register is reset to 0x7C00 (-2^{25}) when the LTC2972 emerges from power-on reset, when a CLEAR_FAULTS command to any page is executed, or a channel goes through an off-to-on transition.

MFR_IIN_MIN

This command returns the minimum ADC measured value of the input current. This register is reset to 0x7BFF (approximately 2^{25}) when the LTC2972 emerges from power-on reset, when a CLEAR_FAULTS command to any page is executed, or a channel goes through an off-to-on transition.

MFR_PIN_PEAK

This command returns the maximum ADC measured value of the input power. This register is reset to 0x7C00 (-2^{25}) when the LTC2972 emerges from power-on reset, when a CLEAR_FAULTS command to any page is executed, or a channel goes through an off-to-on transition.

MFR_PIN_MIN

This command returns the minimum ADC measured value of the input power. This register is reset to 0x7BFF (approximately 2^{25}) when the LTC2972 emerges from power-on reset, when a CLEAR_FAULTS command to any page is executed, or a channel goes through an off-to-on transition.

READ_TEMPERATURE_1

This command returns the most recent measured value of the external diode temperature in °C. This value is used for all temperature related operations and calculations. This command is paged. READ_TEMPERATURE_2 is substituted for READ_TEMPERATURE_1 if the associated T_{SENSE} network fails to detect a valid temperature.

The T_{SENSE} network will fail to detect a valid temperature under the following conditions:

- The T_{SENSE} pin is shorted to a constant voltage.

- The sense diode has an ideality factor greater than N_{TS} max.

Floating the T_{SENSE} pin is not recommended and may return unpredictable temperature values.

READ_TEMPERATURE_2

This command returns the most recent ADC measured value of junction temperature in °C as determined by the LTC2972's internal temperature sensor. This register is for information purposes and does not generate any faults, warnings, or affect any other registers or internal calculations unless it is used as READ_TEMPERATURE_1. This command is not paged.

READ_TEMPERATURE_2 is substituted for READ_TEMPERATURE_1 if a channel's T_{SENSE} network fails to detect a valid temperature.

PMBus COMMAND DESCRIPTION

READ_POUT

This command returns the most recent ADC measured value of the channel's output power in watts.

MFR_READ_IOUT

This command returns the most recent ADC measured value of the channel's output current, using a custom format that provides better numeric representation granularity than the READ_IOUT command for currents whose absolute value is between 2A and 82A.

MFR_READ_IOUT Data Contents

BIT(S)	SYMBOL	OPERATION
b[15:0]	Mfr_read_iout[15:0]	Channel output current expressed in custom format for improved resolution at high currents. Value = $Y \cdot 2.5$ where $Y = b[15:0]$ is a signed two's-complement number. Example: MFR_READ_IOUT = 5mA For b[15:0] = 0x0002 Value = $2 \cdot 2.5 = 5\text{mA}$

The granularity of the returned value is always 2.5mA, and the return value is limited to $\pm 81.92\text{A}$. The READ_IOUT command provides the best resolution for currents less than 2A and must be used for currents larger than 82A. Note that the accuracy of the returned value is always limited by the ADC Characteristics listed in the Electrical Characteristics section.

Table 5. Comparison of Granularity Due to Numeric Format

CURRENT RANGE	READ_IOUT GRANULARITY	MFR_READ_IOUT GRANULARITY
$31.25\text{mA} \leq I_{\text{OUT}} < 62.5\text{mA}$	61 μA	2.5mA
$62.5\text{mA} \leq I_{\text{OUT}} < 125\text{mA}$	122 μA	2.5mA
$125\text{mA} \leq I_{\text{OUT}} < 250\text{mA}$	244 μA	2.5mA
$250\text{mA} \leq I_{\text{OUT}} < 500\text{mA}$	488 μA	2.5mA
$0.5\text{A} \leq I_{\text{OUT}} < 1\text{A}$	977 μA	2.5mA
$1\text{A} \leq I_{\text{OUT}} < 2\text{A}$	1.95mA	2.5mA
$2\text{A} \leq I_{\text{OUT}} < 4\text{A}$	3.9mA	2.5mA
$4\text{A} \leq I_{\text{OUT}} < 8\text{A}$	7.8mA	2.5mA
$8\text{A} \leq I_{\text{OUT}} < 16\text{A}$	15.6mA	2.5mA
$16\text{A} \leq I_{\text{OUT}} < 32\text{A}$	31.3mA	2.5mA
$32\text{A} \leq I_{\text{OUT}} < 64\text{A}$	62.5mA	2.5mA
$64\text{A} \leq I_{\text{OUT}} < 82\text{A}$	125mA	2.5mA
$82\text{A} \leq I_{\text{OUT}} < 128\text{A}$	125mA	Saturated
$128\text{A} \leq I_{\text{OUT}} < 256\text{A}$	250mA	Saturated

PMBus COMMAND DESCRIPTION

MFR_IOUT_SENSE_VOLTAGE

This command returns the absolute value of the voltage measured between I_{SENSEp_n} and I_{SENSEM_n} during the last READ_IOUT ADC conversion without any temperature correction.

MFR_IOUT_SENSE_VOLTAGE Data Contents

BIT(S)	SYMBOL	OPERATION
b[15:0]	Mfr_iout_sense_voltage	<p>Absolute value of raw voltage conversion measured between I_{SENSEp_n} and I_{SENSEM_n}.</p> <p>Value = $Y \cdot X \cdot 2^{-13}$ where $Y = b[15:0]$ is an unsigned integer and $X = 0.025$ or 0.75 if <code>mfr_config_imon_sel = 0</code> or <code>1</code> respectively, resulting in an LSB of $3.05\mu\text{V}$ or $91.5\mu\text{V}$.</p> <p>Example:</p> <p><code>mfr_config_imon_sel = 0</code> <code>MFR_IOUT_SENSE_VOLTAGE = 1.544mV</code> For <code>b[15:0] = 0x1FA = 506</code> Value = $506 \cdot 0.025 \cdot 2^{-13} = 1.544\text{mV}$</p>

MFR_VIN_PEAK

This command returns the maximum ADC measured value of the input voltage. This register is reset to `0x7C00` (-2^{25}) when the LTC2972 emerges from power-on reset, when a CLEAR_FAULTS command to any page is executed, or a channel goes through an off-to-on transition.

MFR_VOUT_PEAK

This command returns the maximum ADC measured value of the channel's output voltage. This register is reset to `0xF800` (0.0) when the LTC2972 emerges from power-on reset, when a CLEAR_FAULTS command to the page is executed, or the channel goes through an off-to-on transition.

MFR_IOUT_PEAK

This command returns the maximum ADC measured value of the channel's output current. This register is reset to `0x7C00` (-2^{25}) when the LTC2972 emerges from power-on reset, when a CLEAR_FAULTS command to the page is executed, or the channel goes through an off-to-on transition.

MFR_TEMPERATURE_1_PEAK

This command returns the maximum measured value of the external diode temperature in $^{\circ}\text{C}$. This register is reset to `0x7C00` (-2^{25}) when the LTC2972 emerges from power-on reset, when a CLEAR_FAULTS command to the page is executed, or the channel goes through an off-to-on transition.

MFR_VIN_MIN

This command returns the minimum ADC measured value of the input voltage. This register is reset to `0x7BFF` (approximately 2^{25}) when the LTC2972 emerges from power-on reset, when a CLEAR_FAULTS command to any page is executed, or a channel goes through an off-to-on transition.

MFR_VOUT_MIN

This command returns the minimum ADC measured value of the channel's output voltage. This register is reset to `0xFFFF` (7.9999) when the LTC2972 emerges from power-on reset, when a CLEAR_FAULTS command to the page is executed, or the channel goes through an off-to-on transition.

PMBus COMMAND DESCRIPTION

MFR_IOUT_MIN

This command returns the minimum ADC measured value of the channel's output current. This register is reset to 0x7BFF (approximately 2^{25}) when the LTC2972 emerges from power-on reset, when a CLEAR_FAULTS command is executed to the page, or the channel goes through an off-to-on transition.

MFR_TEMPERATURE_1_MIN

This command returns the minimum measured value of the external diode temperature in °C. This register is reset to 0x7BFF (approximately 2^{25}) when the LTC2972 emerges from power-on reset, when a CLEAR_FAULTS command is executed to the page, or the channel goes through an off-to-on transition.

FAULT LOGGING

COMMAND NAME	CMD CODE	DESCRIPTION	TYPE	PAGED	FORMAT	UNITS	EEPROM	DEFAULT VALUE	REF PAGE
MFR_FAULT_LOG_STORE	0xEA	Command a transfer of the fault log from RAM to EEPROM.	Send Byte	N				NA	80
MFR_FAULT_LOG_RESTORE	0xEB	Command a transfer of the fault log previously stored in EEPROM back to RAM.	Send Byte	N				NA	80
MFR_FAULT_LOG_CLEAR	0xEC	Initialize the EEPROM block reserved for fault logging and clear any previous fault logging locks.	Send Byte	N				NA	80
MFR_FAULT_LOG_STATUS	0xED	Fault logging status.	R Byte	N	Reg		Y	NA	80
MFR_FAULT_LOG	0xEE	Fault log data bytes. This sequentially retrieved data is used to assemble a complete fault log.	R Block	N	Reg		Y	NA	80

Fault Log Operation

A conceptual diagram of the fault log is shown in Figure 21. The fault log provides black box capability for the LTC2972. During normal operation the contents of the status registers, the output voltage/current/temperature readings, the input voltage readings, as well as peak and min values of these quantities, are stored in a continuously updated buffer in RAM. You can think of the operation as being similar to a strip chart recorder. When a fault occurs, the contents are written into EEPROM for non volatile storage. The EEPROM fault log is then locked. The part can be powered down with the fault log available for reading at a later time.

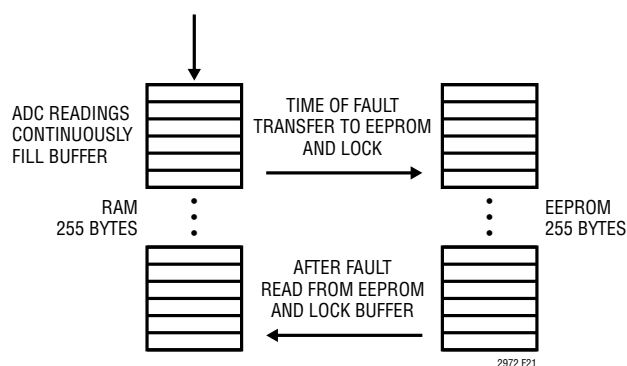

Figure 21. Fault Logging

PMBus COMMAND DESCRIPTION

MFR_FAULT_LOG_STORE

This command allows the user to transfer data from the RAM buffer to EEPROM.

MFR_FAULT_LOG_RESTORE

This command allows the user to transfer a copy of the fault-log data from the EEPROM to the RAM buffer. After a restore the RAM buffer is locked until a successful Mfr_fault_log read.

MFR_FAULT_LOG_CLEAR

This command initializes the EEPROM block reserved for fault logging. Any previous fault log stored in EEPROM will be erased by this operation and logging of the fault log RAM to EEPROM will be enabled. Make sure that Mfr_fault_log_status_ram = 0 before issuing the MFR_FAULT_LOG_CLEAR command.

MFR_FAULT_LOG_STATUS

This register is used to manage fault log events. The Mfr_fault_log_status_eeprom bit is set after a MFR_FAULT_LOG_STORE command or a faulted-off event triggers a transfer of the fault log from RAM to EEPROM. This bit is cleared by a MFR_FAULT_LOG_CLEAR command.

Mfr_fault_log_status_ram is set after a MFR_FAULT_LOG_RESTORE to indicate that the data in the RAM has been restored from EEPROM and not yet read using a MFR_FAULT_LOG command. This bit is cleared only by a successful execution of an MFR_FAULT_LOG command.

MFR_FAULT_LOG_STATUS Data Contents

BIT(S)	SYMBOL	OPERATION
b[7:2]	Reserved	Read only, always returns 0s.
b[1]	Mfr_fault_log_status_ram	Fault log RAM status: 0: The fault log RAM allows updates. 1: The fault log RAM is locked until the next Mfr_fault_log read.
b[0]	Mfr_fault_log_status_eeprom	Fault log EEPROM status: 0: The transfer of the fault log RAM to the EEPROM is enabled. 1: The transfer of the fault log RAM to the EEPROM is inhibited.

MFR_FAULT_LOG

Read only. This 2040-bit (255-byte) data block contains a copy of the RAM buffer fault log. The RAM buffer is continuously updated after each ADC conversion as long as Mfr_fault_log_status_eeprom is clear.

With Mfr_config_fault_log_enable = 1 and Mfr_fault_log_status_eeprom = 0, the RAM buffer is transferred to EEPROM whenever an LTC2972 fault causes a channel to latch off or a MFR_FAULT_LOG_STORE command is received. This transfer is delayed until the ADC has updated its READ values for both channels when Mfr_config_all_fast_fault_log is clear, otherwise it happens within 24ms. This optional delay can be used to ensure that the slower ADC monitored values are all updated for the case where a fast supervisor detected fault initiates the transfer to EEPROM.

Mfr_fault_log_status_eeprom is set high after the RAM buffer is transferred to EEPROM and not cleared until a Mfr_fault_log_clear is received, even if the LTC2972 is reset or powered down. Fault log EEPROM transfers are not initiated as a result of Status_mfr_discharge events.

PMBus COMMAND DESCRIPTION

During a Mfr_fault_log read, data is returned one byte at a time as defined in Table 6. The fault log data is partitioned into two sections. The first section is referred to as the preamble and contains the Position_last pointer, time information and peak and min values. The second section contains a chronological record of telemetry and requires Position_last for proper interpretation. The fault log stores approximately 300ms seconds of telemetry. To prevent timeouts during block reads, it is recommended that Mfr_config_all_longer_pmbus_timeout be set to 1.

Table 6. Data Block Contents

DATA	BYTE*	DESCRIPTION
Position_last[7:0]	0	Position of fault log pointer when fault occurred.
Reserved	1	Always returns 0x00.
SharedTime[7:0]	2	41-bit share-clock counter value when fault occurred. Counter LSB is in 200µs increments. This counter is cleared at power-up or after the LTC2972 is reset.
SharedTime[15:8]	3	
SharedTime[23:16]	4	
SharedTime[31:24]	5	
SharedTime[39:32]	6	
SharedTime[40]	7	
Mfr_first_fault[7:0]	8	Least significant 8 bits of the share-clock counter captured at the time the first fault is detected.
Mfr_first_fault[15:8]	9	
FirstFaultTime	10	
Mfr_vout_peak0[7:0]	11	
Mfr_vout_peak0[15:8]	12	
Mfr_vout_min0[7:0]	13	
Mfr_vout_min0[15:8]	14	
Mfr_temperature_peak0[7:0]	15	
Mfr_temperature_peak0[15:8]	16	
Mfr_temperature_min0[7:0]	17	
Mfr_temperature_min0[15:8]	18	
Mfr_iout_peak0[7:0]	19	
Mfr_iout_peak0[15:8]	20	
Mfr_iout_min0[7:0]	21	
Mfr_iout_min0[15:8]	22	
Mfr_vin_peak[7:0]	23	
Mfr_vin_peak[15:8]	24	
Mfr_vin_min[7:0]	25	

Table 6. Data Block Contents

DATA	BYTE*	DESCRIPTION
Mfr_vin_min[15:8]	26	
Mfr_iin_peak[7:0]	27	
Mfr_iin_peak[15:8]	28	
Mfr_iin_min[7:0]	29	
Mfr_iin_min[15:8]	30	
Mfr_pin_peak[7:0]	31	
Mfr_pin_peak[15:8]	32	
Mfr_pin_min[7:0]	33	
Mfr_pin_min[15:8]	34	
Mfr_vout_peak1[7:0]	35	
Mfr_vout_peak1[15:8]	36	
Mfr_vout_min1[7:0]	37	
Mfr_vout_min1[15:8]	38	
Mfr_temperature_peak1[7:0]	39	
Mfr_temperature_peak1[15:8]	40	
Mfr_temperature_min1[7:0]	41	
Mfr_temperature_min1[15:8]	42	
Mfr_iout_peak1[7:0]	43	
Mfr_iout_peak1[15:8]	44	
Mfr_iout_min1[7:0]	45	
Mfr_iout_min1[15:8]	46	
Status_vout0[7:0]	47	
Status_iout0[7:0]	48	
Status_mfr_specific0[7:0]	49	
Mfr_status_2_0[7:0]	50	Reserved bits[15:8] not stored
Status_vout1[7:0]	51	
Status_iout1[7:0]	52	
Status_mfr_specific1[7:0]	53	
Mfr_status_2_1[7:0]	54	
		55 bytes for preamble
Fault_log [Position_last]	55	
Fault_log [Position_last-1]	56	
...		
Fault_log [Position_last-170]	237	
Reserved	238-254	
		Number of loops: (238 – 55)/36 = 5.08

*Note that PMBus data byte numbers start at 1 rather than 0. Position_last is the first byte returned after BYTE_COUNT = 0xFF. See block read protocol.

PMBus COMMAND DESCRIPTION

The data returned between bytes 55 and 237 of the previous table is interpreted using Position_last and the following table. The key to identifying the data located in byte 55 is to locate the DATA corresponding to POSITION = Position_last in the next table. Subsequent bytes are identified by decrementing the value of POSITION. For example: If Position_last = 9 then the first data returned in byte position 55 of a block read is Status_temperature of page 0 followed by Read_temperature_1[15:8] of page 0 followed by Read_temperature_1[7:0] of page 0 and so on. See Table 7.

Table 7. Interpreting Cyclical Loop Data

POSITION	DATA
0	Read_temperature_2[7:0]
1	Read_temperature_2[15:8]
2	Read_vout0[7:0]
3	Read_vout0[15:8]
4	Status_vout0[7:0]
5	Status_mfr_specific0[7:0]
6	Mfr_status_2_0[7:0]
7	Read_temperature_1_0[7:0]
8	Read_temperature_1_0[15:8]
9	Status_temperature0[7:0]
10	Status_iout0[7:0]
11	Read_iout0[7:0]
12	Read_iout0[15:8]

Table 7. Interpreting Cyclical Loop Data

POSITION	DATA
13	Read_pout0[7:0]
14	Read_pout0[15:8]
15	Read_vin[7:0]
16	Read_vin[15:8]
17	Status_input[7:0]
18	0x0
19	Read_iin[7:0]
20	Read_iin[15:8]
21	Read_pin[7:0]
22	Read_pin[15:8]
23	Read_vout1[7:0]
24	Read_vout1[15:8]
25	Status_vout1[7:0]
26	Status_mfr_specific1[7:0]
27	Mfr_status_2_1[7:0]
28	Read_temperature_1_1[7:0]
29	Read_temperature_1_1[15:8]
30	Status_temperature1[7:0]
31	Status_iout1[7:0]
32	Read_iout1[7:0]
33	Read_iout1[15:8]
34	Read_pout1[7:0]
35	Read_pout1[15:8]
	Total Bytes = 36

PMBus COMMAND DESCRIPTION

MFR_FAULT_LOG Read Example

The following table fully decodes a sample fault log read with Position_last = 4 to help clarify the cyclical nature of the operation.

Data Block Contents

PREAMBLE INFORMATION			
BYTE NUMBER DECIMAL	BYTE NUMBER HEX	DATA	DESCRIPTION
0	00	Position_last[7:0] = 4	Position of fault-log pointer when fault occurred.
1	01	Reserved	Always returns 0x00.
2	02	SharedTime[7:0]	41-bit share-clock counter value when fault occurred. Counter LSB is in 200µs increments.
3	03	SharedTime[15:8]	
4	04	SharedTime[23:16]	
5	05	SharedTime[31:24]	
6	06	SharedTime[39:32]	
7	07	SharedTime[40]	
8	08	Mfr_first_fault[7:0]	
9	09	Mfr_first_fault[15:8]	
10	0A	FirstFaultTime	
11	0B	Mfr_vout_peak0[7:0]	
12	0C	Mfr_vout_peak0[15:8]	
13	0D	Mfr_vout_min0[7:0]	
14	0E	Mfr_vout_min0[15:8]	
15	0F	Mfr_temperature_peak0[7:0]	
16	10	Mfr_temperature_peak0[15:8]	
17	11	Mfr_temperature_min0[7:0]	
18	12	Mfr_temperature_min0[15:8]	
19	13	Mfr_iout_peak0[7:0]	
20	14	Mfr_iout_peak0[15:8]	
21	15	Mfr_iout_min0[7:0]	
22	16	Mfr_iout_min0[15:8]	
23	17	Mfr_vin_peak_[7:0]	
24	18	Mfr_vin_peak_[15:8]	
25	19	Mfr_vin_min_[7:0]	
26	1A	Mfr_vin_min_[15:8]	

PREAMBLE INFORMATION

BYTE NUMBER DECIMAL	BYTE NUMBER HEX	DATA	DESCRIPTION
27	1B	Mfr_iin_peak[7:0]	
28	1C	Mfr_iin_peak[15:8]	
29	1D	Mfr_iin_min[7:0]	
30	1E	Mfr_iin_min[15:8]	
31	1F	Mfr_pin_peak[7:0]	
32	20	Mfr_pin_peak[15:8]	
33	21	Mfr_pin_min[7:0]	
34	22	Mfr_pin_min[15:8]	
35	23	Mfr_vout_peak1[7:0]	
36	24	Mfr_vout_peak1[15:8]	
37	25	Mfr_vout_min1[7:0]	
38	26	Mfr_vout_min1[15:8]	
39	27	Mfr_temperature_peak1[7:0]	
40	28	Mfr_temperature_peak1[15:8]	
41	29	Mfr_temperature_min1[7:0]	
42	2A	Mfr_temperature_min1[15:8]	
43	2B	Mfr_iout_peak1[7:0]	
44	2C	Mfr_iout_peak1[15:8]	
45	2D	Mfr_iout_min1[7:0]	
46	2E	Mfr_iout_min1[15:8]	
47	2F	Status_vout0[7:0]	
48	30	Status_iout0[7:0]	
49	31	Status_mfr_specific0[7:0]	
50	32	Mfr_status_2_0[7:0]	
51	33	Status_vout1[7:0]	
52	34	Status_iout1[7:0]	
53	35	Status_mfr_specific1[7:0]	
54	36	Mfr_status_2_1[7:0]	End of Preamble

PMBus COMMAND DESCRIPTION

CYCLICAL MUX LOOP DATA

BYTE NUMBER DECIMAL	BYTE NUMBER HEX	LOOP BYTE NUMBER DECIMAL	DATA LOOP 0	36 BYTES PER LOOP
55	37	4	Status_vout0[7:0]	Position_last
56	38	3	Read_vout0[15:8]	
57	39	2	Read_vout0[7:0]	
58	40	1	Read_temperature_2[15:8]	
59	41	0	Read_temperature_2[7:0]	

CYCLICAL MUX LOOP DATA

BYTE NUMBER DECIMAL	BYTE NUMBER HEX	LOOP BYTE NUMBER DECIMAL	DATA LOOP 1	36 BYTES PER LOOP
60	3C	35	Read_pout1[15:8]	
61	3D	34	Read_pout1[7:0]	
62	3E	33	Read_iout1[15:8]	
63	3F	32	Read_iout1[7:0]	
64	40	31	Status_iout1[7:0]	
65	41	30	Status_temperature2[7:0]	
66	42	29	Read_temperature_1_1[15:8]	
67	43	28	Read_temperature_1_1[7:0]	
68	44	27	Mfr_status_2_1[7:0]	
69	45	26	Status_mfr_specific1[7:0]	
70	46	25	Status_vout1[7:0]	
71	47	24	Read_vout1[15:8]	
72	48	23	Read_vout1[7:0]	
73	49	22	Read_pin[15:8]	
74	4A	21	Read_pin[7:0]	
75	4B	20	Read_in[15:8]	
76	4C	19	Read_in[7:0]	
77	4D	18	0x0	
78	4E	17	Status_input[7:0]	
79	4F	16	Read_vin[15:8]	
80	50	15	Read_vin[7:0]	
81	51	14	Read_pout0[15:8]	
82	52	13	Read_pout0[7:0]	
83	53	12	Read_iout0[15:8]	

CYCLICAL MUX LOOP DATA

BYTE NUMBER DECIMAL	BYTE NUMBER HEX	LOOP BYTE NUMBER DECIMAL	DATA LOOP 1	36 BYTES PER LOOP
84	54	11	Read_iout0[7:0]	
85	55	10	Status_iout0[7:0]	
86	56	9	Status_temperature0[7:0]	
87	57	8	Read_temperature_1_0[15:8]	
88	58	7	Read_temperature_1_0[7:0]	
89	59	6	Mfr_status_2_0[7:0]	
90	5A	5	Status_mfr_specific0[7:0]	
91	5B	4	Status_vout0[7:0]	
92	5C	3	Read_vout0[15:8]	
93	5D	2	Read_vout0[7:0]	
94	5E	1	Read_temperature_2[15:8]	
95	5F	0	Read_temperature_2[7:0]	

CYCLICAL MUX LOOP DATA

BYTE NUMBER DECIMAL	BYTE NUMBER HEX	LOOP BYTE NUMBER DECIMAL	DATA LOOP 2	36 BYTES PER LOOP
96	60	35	Read_pout1[15:8]	
97	61	34	Read_pout1[7:0]	
98	62	33	Read_iout1[15:8]	
99	63	32	Read_iout1[7:0]	
100	64	31	Status_iout1[7:0]	
101	65	30	Status_temperature2[7:0]	
102	66	29	Read_temperature_1_1[15:8]	
103	67	28	Read_temperature_1_1[7:0]	
104	68	27	Mfr_status_2_1[7:0]	
105	69	26	Status_mfr_specific1[7:0]	
106	6A	25	Status_vout1[7:0]	
107	6B	24	Read_vout1[15:8]	
108	6C	23	Read_vout1[7:0]	
109	6D	22	Read_pin[15:8]	

PMBus COMMAND DESCRIPTION

CYCLICAL MUX LOOP DATA

BYTE NUMBER DECIMAL	BYTE NUMBER HEX	LOOP BYTE NUMBER DECIMAL	DATA LOOP 2	36 BYTES PER LOOP
110	6E	21	Read_pin[7:0]	
111	6F	20	Read_in[15:8]	
112	70	19	Read_in[7:0]	
113	71	18	0x0	
114	72	17	Status_input[7:0]	
115	73	16	Read_vin[15:8]	
116	74	15	Read_vin[7:0]	
117	75	14	Read_pout0[15:8]	
118	76	13	Read_pout0[7:0]	
119	77	12	Read_iout0[15:8]	
120	78	11	Read_iout0[7:0]	
121	79	10	Status_iout0[7:0]	
122	7A	9	Status_temperature0[7:0]	
123	7B	8	Read_temperature_1_0[15:8]	
124	7C	7	Read_temperature_1_0[7:0]	
125	7D	6	Mfr_status_2_0[7:0]	
126	7E	5	Status_mfr_specific0[7:0]	
127	7F	4	Status_vout0[7:0]	
128	80	3	Read_vout0[15:8]	
129	81	2	Read_vout0[7:0]	
130	82	1	Read_temperature_2[15:8]	
131	83	0	Read_temperature_2[7:0]	

CYCLICAL MUX LOOP DATA

BYTE NUMBER DECIMAL	BYTE NUMBER HEX	LOOP BYTE NUMBER DECIMAL	DATA LOOP 3	36 BYTES PER LOOP
133	85	35	Read_pout1[15:8]	
134	86	34	Read_pout1[7:0]	
135	87	33	Read_iout1[15:8]	
136	88	32	Read_iout1[7:0]	
137	89	31	Status_iout1[7:0]	
138	8A	30	Status_temperature2[7:0]	

CYCLICAL MUX LOOP DATA

BYTE NUMBER DECIMAL	BYTE NUMBER HEX	LOOP BYTE NUMBER DECIMAL	DATA LOOP 3	36 BYTES PER LOOP
139	8B	29	Read_temperature_1_1[15:8]	
140	8C	28	Read_temperature_1_1[7:0]	
141	8D	27	Mfr_status_2_1[7:0]	
142	8E	26	Status_mfr_specific1[7:0]	
143	8F	25	Status_vout1[7:0]	
144	90	24	Read_vout1[15:8]	
145	91	23	Read_vout1[7:0]	
146	92	22	Read_pin[15:8]	
147	93	21	Read_pin[7:0]	
148	94	20	Read_in[15:8]	
149	95	19	Read_in[7:0]	
150	96	18	0x0	
151	97	17	Status_input[7:0]	
152	98	16	Read_vin[15:8]	
153	99	15	Read_vin[7:0]	
154	9A	14	Read_pout0[15:8]	
155	9B	13	Read_pout0[7:0]	
156	9C	12	Read_iout0[15:8]	
157	9D	11	Read_iout0[7:0]	
158	9E	10	Status_iout0[7:0]	
159	9F	9	Status_temperature0[7:0]	
160	A0	8	Read_temperature_1_0[15:8]	
161	A1	7	Read_temperature_1_0[7:0]	
162	A2	6	Mfr_status_2_0[7:0]	
163	A3	5	Status_mfr_specific0[7:0]	
164	A4	4	Status_vout0[7:0]	
165	A5	3	Read_vout0[15:8]	
166	A6	2	Read_vout0[7:0]	
167	A7	1	Read_temperature_2[15:8]	
168	A8	0	Read_temperature_2[7:0]	

PMBus COMMAND DESCRIPTION

CYCLICAL MUX LOOP DATA

BYTE NUMBER DECIMAL	BYTE NUMBER HEX	LOOP BYTE NUMBER DECIMAL	DATA LOOP 4	36 BYTES PER LOOP
169	A9	35	Read_pout1[15:8]	
170	AA	34	Read_pout1[7:0]	
171	AB	33	Read_iout1[15:8]	
172	AC	32	Read_iout1[7:0]	
173	AD	31	Status_iout1[7:0]	
174	AE	30	Status_temperature2[7:0]	
175	AF	29	Read_temperature_1_1[15:8]	
176	B0	28	Read_temperature_1_1[7:0]	
177	B1	27	Mfr_status_2_1[7:0]	
178	B2	26	Status_mfr_specific1[7:0]	
179	B3	25	Status_vout1[7:0]	
180	B4	24	Read_vout1[15:8]	
181	B5	23	Read_vout1[7:0]	
182	B6	22	Read_pin[15:8]	
183	B7	21	Read_pin[7:0]	
184	B8	20	Read_in[15:8]	
185	B9	19	Read_in[7:0]	
186	BA	18	0x0	
187	BB	17	Status_input[7:0]	
188	BC	16	Read_vin[15:8]	
189	BD	15	Read_vin[7:0]	
190	BE	14	Read_pout0[15:8]	
191	BF	13	Read_pout0[7:0]	
192	C0	12	Read_iout0[15:8]	
193	C1	11	Read_iout0[7:0]	
194	C2	10	Status_iout0[7:0]	
195	C3	9	Status_temperature0[7:0]	

CYCLICAL MUX LOOP DATA

BYTE NUMBER DECIMAL	BYTE NUMBER HEX	LOOP BYTE NUMBER DECIMAL	DATA LOOP 4	36 BYTES PER LOOP
196	C4	8	Read_temperature_1_0[15:8]	
197	C5	7	Read_temperature_1_0[7:0]	
198	C6	6	Mfr_status_2_0[7:0]	
199	C7	5	Status_mfr_specific0[7:0]	
200	C8	4	Status_vout0[7:0]	
201	C9	3	Read_vout0[15:8]	
202	CA	2	Read_vout0[7:0]	
203	CB	1	Read_temperature_2[15:8]	
204	CC	0	Read_temperature_2[7:0]	

CYCLICAL MUX LOOP DATA

BYTE NUMBER DECIMAL	BYTE NUMBER HEX	LOOP BYTE NUMBER DECIMAL	DATA LOOP 5	36 BYTES PER LOOP
205	CD	35	Read_pout1[15:8]	
206	CE	34	Read_pout1[7:0]	
207	CF	33	Read_iout1[15:8]	
208	D0	32	Read_iout1[7:0]	
209	D1	31	Status_iout1[7:0]	
210	D2	30	Status_temperature2[7:0]	
211	D3	29	Read_temperature_1_1[15:8]	
212	D4	28	Read_temperature_1_1[7:0]	
213	D5	27	Mfr_status_2_1[7:0]	
214	D6	26	Status_mfr_specific1[7:0]	
215	D7	25	Status_vout1[7:0]	
216	D8	24	Read_vout1[15:8]	
217	D9	23	Read_vout1[7:0]	
218	DA	22	Read_pin[15:8]	
219	DB	21	Read_pin[7:0]	
220	DC	20	Read_in[15:8]	
221	DD	19	Read_in[7:0]	

PMBus COMMAND DESCRIPTION

CYCLICAL MUX LOOP DATA

BYTE NUMBER DECIMAL	BYTE NUMBER HEX	LOOP BYTE NUMBER DECIMAL	DATA LOOP 5	36 BYTES PER LOOP
222	DE	18	0x0	
223	DF	17	Status_input[7:0]	
224	E0	16	Read_vin[15:8]	
225	E1	15	Read_vin[7:0]	
226	E2	14	Read_pout0[15:8]	
227	E3	13	Read_pout0[7:0]	
228	E4	12	Read_iout0[15:8]	
229	E5	11	Read_iout0[7:0]	
230	E6	10	Status_iout0[7:0]	
231	E7	9	Status_temperature0[7:0]	
232	E8	8	Read_temperature_1_0[15:8]	
233	E9	7	Read_temperature_1_0[7:0]	
234	EA	6	Mfr_status_2_0[7:0]	
235	EB	5	Status_mfr_specific0[7:0]	
236	EC	4	Status_vout0[7:0]	
237	ED	3	Read_vout0[15:8]	Last valid fault log byte

RESERVED BYTES

BYTE NUMBER DECIMAL	BYTE NUMBER HEX	DATA	36 BYTES PER LOOP	Notes
238	EE	0x00		Bytes EE – FE Return 0x00 But Must Be Read
239	EF	0x00		
240	F0	0x00		
241	F1	0x00		
242	F2	0x00		
243	F3	0x00		
244	F4	0x00		
245	F5	0x00		
246	F6	0x00		
247	F7	0x00		
248	F8	0x00		
249	F9	0x00		
250	FA	0x00		
251	FB	0x00		
252	FC	0x00		
253	FD	0x00		
254	FE	0x00		
				Use One Block Read Command to Read 255 Bytes Total, from 0x00 to 0xFE

PMBus COMMAND DESCRIPTION

IDENTIFICATION/INFORMATION

COMMAND NAME	CMD CODE	DESCRIPTION	TYPE	PAGED	FORMAT	UNITS	EEPROM	DEFAULT VALUE	REF PAGE
CAPABILITY	0x19	Summary of PMBus optional communication protocols supported by this device.	R Byte	N	Reg			0xB0	88
PMBUS_REVISION	0x98	PMBus revision supported by this device. Current revision is 1.1.	R Byte	N	Reg			0x11	88
MFR_SPECIAL_ID	0xE7	Manufacturer code for identifying the LTC2972.	R Word	N	Reg		Y	784 0x0310	88
MFR_SPECIAL_LOT	0xE8	Customer dependent codes that identify the factory programmed user configuration stored in EEPROM. Contact factory for default value.	R Byte	Y	Reg		Y		88
MFR_INFO	0xB6	Manufacturer Specific Information	R Word	N	Reg			NA	89

CAPABILITY

The CAPABILITY command provides a way for a host system to determine some key capabilities of the LTC2972.

CAPABILITY Data Contents

BIT(S)	SYMBOL	OPERATION
b[7]	Capability_pec	Hard coded to 1 indicating Packet Error Checking is supported. Reading the Mfr_config_all_pec_en bit will indicate whether PEC is currently required.
b[6:5]	Capability_scl_max	Hard coded to 01b indicating the maximum supported bus speed is 400kHz.
b[4]	Capability_smb_alert	Hard coded to 1 indicating this device does have an ALERTB pin and does support the SMBus Alert Response Protocol.
b[3:0]	Reserved	Always returns 0.

PMBUS_REVISION

PMBUS_REVISION Data Contents

BIT(S)	SYMBOL	OPERATION
b[7:0]	PMBus_rev	Reports the PMBus standard revision compliance. This is hard-coded to 0x11 for revision 1.1.

MFR_SPECIAL_ID

This register contains the manufacturer ID for the LTC2972. Always returns 0x0310.

MFR_SPECIAL_LOT

These paged registers contain information that identifies the user configuration that was programmed at the factory. Contact the factory to request a custom factory programmed user configuration and special lot number.

PMBus COMMAND DESCRIPTION

MFR_INFO

The MFR_INFO register contains manufacturer specific information and is updated after a power-on reset, a RESTORE_USER_ALL command, or an EEPROM bulk read operation.

MFR_INFO Data Contents

BIT(S)	SYMBOL	OPERATION
b[15:6]	Reserved	Reserved
b[5]	Mfr_info_ecc_user	EEPROM ECC status. 0: Corrections made in the EEPROM user space 1: No corrections made in the EEPROM user space
b[4:0]	Reserved	Reserved

USER SCRATCHPAD

COMMAND NAME	CMD CODE	DESCRIPTION	TYPE	PAGED	FORMAT	UNITS	EEPROM	DEFAULT VALUE	REF PAGE
USER_DATA_00	0xB0	Manufacturer reserved for LTpowerPlay.	R/W Word	N	Reg		Y	N/A	89
USER_DATA_01	0xB1	Manufacturer reserved for LTpowerPlay.	R/W Word	Y	Reg		Y	N/A	89
USER_DATA_02	0xB2	OEM Reserved.	R/W Word	N	Reg		Y	N/A	89
USER_DATA_03	0xB3	Scratchpad location.	R/W Word	Y	Reg		Y	0x0000	89
USER_DATA_04	0xB4	Scratchpad location.	R/W Word	N	Reg		Y	0x0000	89
MFR_LTC_RESERVED_2	0xBC	Manufacturer reserved.	R/W Word	Y	Reg			NA	89

USER_DATA_00, USER_DATA_01, USER_DATA_02, USER_DATA_03, USER_DATA_04 and MFR_LTC_RESERVED_2

These registers are provided as user scratchpad and additional manufacturer reserved locations.

USER_DATA_03 and USER_DATA_04 are available for user scratchpad use. These 10 bytes (1 unpagged word plus 2 pagged words) might be used for traceability or revision information such as serial number, board model number, assembly location, or assembly date.

APPLICATIONS INFORMATION

OVERVIEW

The LTC2972 is a 2-channel Power System Management IC that is capable of sequencing, margining, trimming, supervising output voltage for OV/UV conditions, fault management, voltage/current/ temperature readback for two DC/DC converter channels, and readback of high side input current, input voltage, input power, input energy, and junction temperature. Multiple Analog Devices Power System Managers can coordinate operation using the SHARE_CLK, FAULTB, and CONTROL pins. The LTC2972 utilizes a PMBus compliant interface and command set.

POWERING THE LTC2972

The LTC2972 can be powered two ways. The first method requires that a voltage between 4.5V and 15V be applied to the V_{PWR} pin. See Figure 22. An internal linear regulator converts V_{PWR} down to 3.3V which drives all of the internal circuitry of the LTC2972.

Alternatively, power from an external 3.3V supply may be applied directly to the V_{DD33} pins 6 and 7 using a voltage between 3.13V and 3.47V. See Figure 23. Tie V_{PWR} to the V_{DD33} pins. All functionality is available when using this

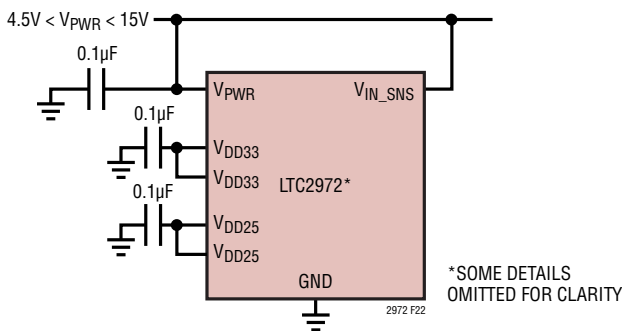

Figure 22. Powering LTC2972 Directly from an Intermediate Bus

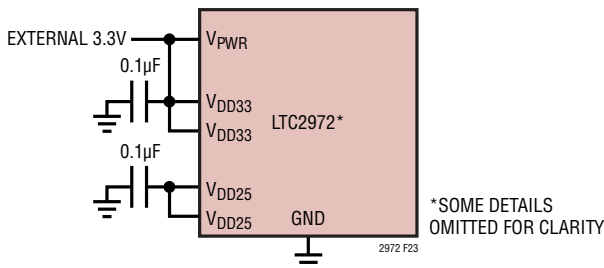

Figure 23. Powering LTC2972 from External 3.3V Supply

alternate power method. The higher voltages needed for the V_{OUT_EN} pins and bias for the V_{SENSE} pins are charge pumped from V_{DD33} .

SETTING COMMAND REGISTER VALUES

The command register settings described herein are intended as a reference and for the purpose of understanding the registers in a software development environment. In actual practice, the LTC2972 can be completely configured for stand-alone operation with the DC1613 USB to I²C/SMBus/ PMBus controller and software GUI using intuitive menu driven objects.

MEASURING INPUT CURRENT

The LTC2972 is capable of measuring the current of the input power source. The device also measures the input supply voltage, enabling it to calculate input power. The LTC2972 has an accurate internal time base allowing the chip to calculate input energy since energy is the product of power and time. The units for each of the measured parameters are amps, volts, watts, and millijoules.

Input current is measured by placing a sense resistor, R_{SENSE} , in series with the desired current load path as shown in Figure 24. If R_{SENSE} has low thermal drift characteristics, the MFR_IIN_CAL_GAIN_TC register value may be set to zero. Otherwise, choose a setting for the MFR_IIN_CAL_GAIN_TC value in units of ppm/°C to correct for R_{SENSE} thermal drift.

For best results, it is recommended to locate R_{SENSE} close to and isothermal with the LTC2972.

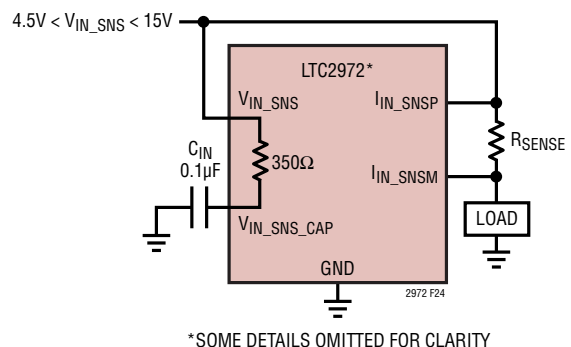

Figure 24. Measuring Input Current

APPLICATIONS INFORMATION

The input current sense path includes an internal, anti-aliasing low pass filter with typical 32dB rejection at 62.5kHz. To improve high frequency current sense common mode rejection, add a 0.01 μ F capacitor, C_{IN} , to the $V_{IN_SNS_CAP}$ pin.

The $Mfr_ein_config_iin_range$ bits select one of three input current sense amplifier ranges: high, medium and low. The R_{SENSE} value should be chosen to satisfy the input range. The maximum allowable input ranges are as follows: ± 100 mV range for high range, ± 50 mV for medium range and ± 20 mV for low range. For best accuracy, use the lowest range setting encompassing the maximum input signal.

To help choose the R_{SENSE} value and $Mfr_ein_config_iin_range$ setting for your application, use the Electrical Characteristics table for TUE_IIN, along with Figure 25 and Figure 26. Figure 25 and Figure 26 serve as extrapolated guides while the Electrical Characteristics table shows tested TUE_IIN conditions. After selecting R_{SENSE} , write its value in m Ω to the $MFR_IIN_CAL_GAIN$ register, and $READ_IIN$ will return the sensed current in amps. Figures 25 and 26 show absolute value of the expected worst case $READ_IIN$ Total Unadjusted Error, TUE_IIN, in μ V and in relative % of current sense input voltage reading, V_{IIN_SNS} , as a function of V_{IIN_SNS} ($V_{IIN_SNSP} - V_{IIN_SNSM}$) for high range, medium range and low range settings.

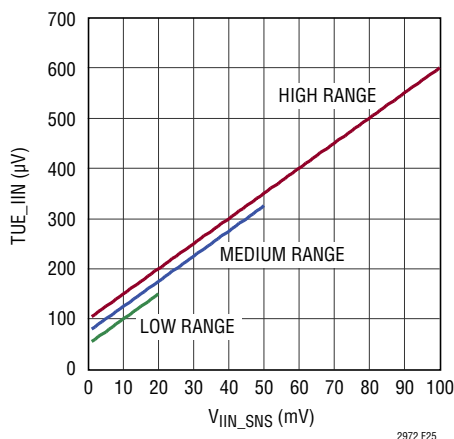

Figure 25. TUE_IIN vs READ_IIN Input Voltage in μ V

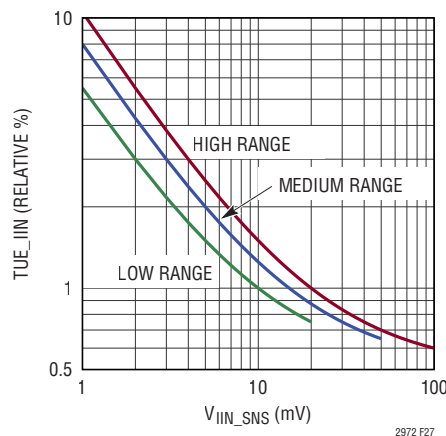

Figure 26. TUE_IIN vs READ_IIN Input Voltage in Percentage

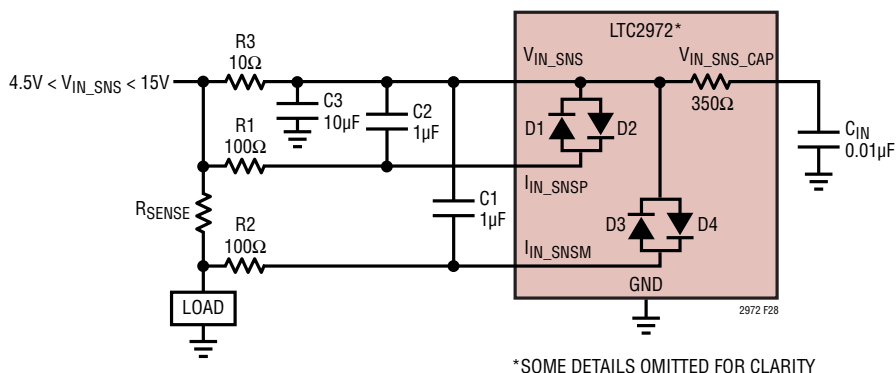

Figure 27. Optional V_{IIN_SNS} Filtering

APPLICATIONS INFORMATION

MEASURING INPUT VOLTAGE

READ_VIN returns input voltage on the V_{IN_SNS} pin. TUE_VIN reflects READ_VIN measurement error. Large ripple on the V_{IN_SNS} pin may affect READ_VIN, READ_PIN, and MFR_EIN accuracy. To reduce ripple induced measurement errors, consider adding the optional anti-aliasing filter components shown in Figure 27. R3 and C3 filter V_{IN_SNS} with 30dB attenuation at 62.5kHz. R1, R2, C1, C2 add additional filtering for IIN_SNS inputs and prevent the internal diodes, D1 to D4, from turning on.

MEASURING INPUT POWER

READ_PIN returns input power in watts calculated from the product of the most recent V_{VIN_SNS} and I_{IN_SNS} measurements. Although the Electrical Characteristics table only specifies READ_PIN Total Unadjusted Error (TUE_PIN) under typical conditions, TUE_PIN is actually bounded by the sum of TUE_IIN and TUE_VIN.

$$TUE_PIN \leq TUE_IIN + TUE_VIN$$

For example, if $15\text{mV} < |V_{IIN_SNS}| < 50\text{mV}$ with the current sense amplifier set for medium range, $TUE_IIN \leq 1\%$ and TUE_PIN is less than $1\% (TUE_IIN) + 0.5\% (TUE_VIN) = 1.5\%$.

Since current sense ranges include positive and negative inputs, READ_PIN returns signed values indicating power transfer magnitude and direction.

MEASURING INPUT ENERGY

The 12 byte data block, MFR_EIN, contains a 48-bit accumulated energy measurement in mJ, Energy_value[47:0], and a 48-bit elapsed time in milliseconds since energy began accumulating, Energy_time[47:0]. Refer to INPUT CURRENT AND ENERGY and MFR_COMMAND_PLUS sections of the PMBUS COMMAND DESCRIPTION for accumulated energy and elapsed time data access details. Energy_value can accumulate up to $(2^{48}-1)$ mJ of energy before wrapping. Energy can accumulate for $(2^{48}-1)$ ms, or about 8925 years, before Energy_time wraps. Accumulation of negative power measurements decreases Energy_value, and the energy meter saturates when it reaches 0 millijoules.

The energy meter time base error (TUE_ETB) specifies error in the internal energy time base accuracy: Energy_time is accurate with maximum error of TUE_ETB. Accumulated energy includes errors from current sense measurements, voltage sense measurements, and the internal time base. Energy_value error (TUE_EIN) is bounded by the summation of TUE_IIN, TUE_VIN, and TUE_ETB:

$$TUE_EIN \leq TUE_IIN + TUE_VIN + TUE_ETB$$

For example, if $V_{IIN_SNS} = 20\text{mV}$ with high current sense amplifier range, TUE_IIN is less than 1% error, TUE_VIN is less than 0.5% error, and TUE_ETB is less than 1% error. Therefore the energy measurement error (TUE_EIN) is less than 2.5%.

SEQUENCE, SERVO, MARGIN AND RESTART OPERATIONS

Command Units On or Off

Three control parameters determine how a particular channel is turned on and off: The CONTROL pins, the OPERATION command and the value of the input voltage measured at the V_{IN_SNS} pin (V_{IN}). In all cases, V_{IN} must exceed VIN_ON in order to enable the device to respond to the CONTROL pins or OPERATION commands. When V_{IN} drops below VIN_OFF an immediate OFF or sequence off after TOFF_DELAY of both channels will result (See Mfr_config_track_en). Refer to the OPERATION section in the data sheet for a detailed description of the ON_OFF_CONFIG command.

Some examples of typical ON/OFF configurations are:

1. A DC/DC converter may be configured to turn on any time V_{IN} exceeds VIN_ON.
2. A DC/DC converter may be configured to turn on only when it receives an OPERATION command.
3. A DC/DC converter may be configured to turn on only via the CONTROL pin.
4. A DC/DC converter may be configured to turn on only when it receives an OPERATION command and the CONTROL pin is asserted.

APPLICATIONS INFORMATION

On Sequencing

The TON_DELAY command sets the amount of time that a channel will wait following the start of an ON sequence before its V_{OUT_EN} pin will enable a DC/DC converter. Once the DC/DC converter has been enabled, the TON_RISE value determines the time at which the device soft-connects the DAC and servos the DC/DC converter output to the VOUT_COMMAND value. The TON_MAX_FAULT_LIMIT value determines the time at which the device checks for an undervoltage condition. If a TON_MAX_FAULT occurs, the channel can be configured to disable the DC/DC converter and propagate the fault to other channels using the bidirectional FAULTB pins. Figure 28 shows a typical on-sequence using the CONTROL pin. Note that overvoltage faults are checked against the VOUT_OV_FAULT_LIMIT value at all times the device is powered up and not in a reset state nor margining while ignoring OVs.

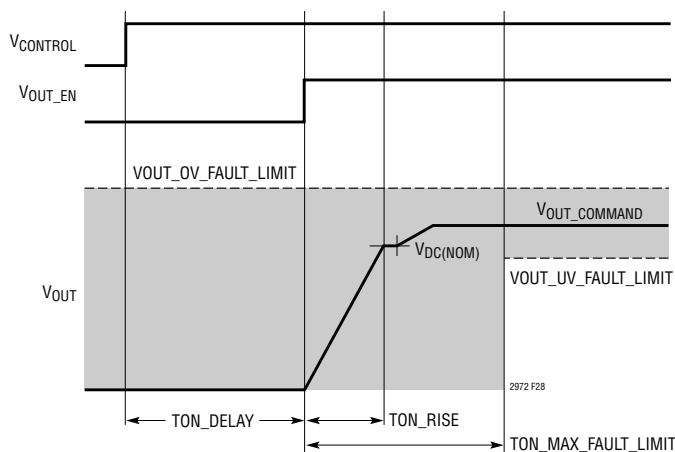

Figure 28. Typical ON Sequence Using Control Pin

On State Operation

Once a channel has reached the ON state, the OPERATION command can be used to command the DC/DC converter's output to margin high, margin low, or return to a nominal output voltage indicated by VOUT_COMMAND. The user also has the option of configuring a channel to continuously trim the output of the DC/DC converter to the VOUT_COMMAND voltage, or the channel's V_{DACn} output can be placed in a high impedance state thus allowing the DC/DC converter output voltage to go to its nominal value,

V_{DCn(NOM)}. Refer to the MFR_CONFIG_LTC2972 command for details on how to configure the output voltage servo.

Servo Modes

The ADC, DAC and internal processor comprise a digital servo loop that can be configured to operate in several useful modes. The servo target refers to the desired output voltage.

Continuous/non-continuous trim mode: MFR_CONFIG_LTC2972 b[7]. In continuous trim mode, the servo will update the DAC in a closed loop fashion each time it takes a V_{OUT} reading. The update rate is determined by the time it takes to step through the ADC MUX which is no more than t_{UPDATE_ADC}. See Electrical Characteristics table Note 6. In non-continuous trim mode, the servo will drive the DAC until the ADC measures the output voltage desired and then stop updating the DAC.

As part of continuous/noncontinuous trim mode, fast servo mode can be used to speed up large output transitions, such as margin commands, or ON events. To use, set Mfr_config_fast_servo_off = 0. When enabled, fast servo is started by a change to the target voltage or a new soft connect. The DAC is ramped one LSB every t_{S_VDAC} period until it is near the new target voltage, at which point slow servo mode is entered to avoid overshoot.

Non-continuous servo on warn mode: MFR_CONFIG_LTC2972 b[7] = 0, b[6] = 1. When in non-continuous mode, the LTC2972 will re-trim (re-servo) the output if the output drifts beyond the OV or UV warn limits.

DAC Modes

The DACs that drive the V_{DACn} pins can operate in several useful modes. See MFR_CONFIG_LTC2972.

- Soft-connect. Using the ADI patented soft-connect feature, the DAC output is driven to within 1LSB of the voltage at the DC/DC's feedback node before connecting, to avoid introducing transients on the output. This mode is used when servoing the output voltage. During startup, the LTC2972 waits until TON_RISE has expired before connecting the DAC. This is the most common operating mode.
- Disconnected. DAC output is high Z.

APPLICATIONS INFORMATION

- DAC manual with soft-connect. Non servo mode. The DAC soft connects to the feedback node. Soft-connect drives the DAC code to match the voltage at the feedback node. After connection, the DAC is moved by writing DAC codes to the MFR_DAC.
- DAC manual with hard connect. Non servo mode. The DAC hard connects to the feedback node using the current value in MFR_DAC. After connection, the DAC is moved by writing DAC codes to the MFR_DAC.

Margining

The LTC2972 margins and trims the output of a DC/DC converter by forcing a voltage across an external resistor connected between the DAC output and the feedback node or the trim pin. Preset limits for margining are stored in the VOUT_MARGIN_HIGH/LOW registers. Margining is actuated by writing the appropriate bits to the OPERATION register.

Margining requires the DAC to be connected. Margin requests that occur when the DAC is disconnected will be ignored.

Off Sequencing

An off sequence is initiated using the CONTROL pin or the OPERATION command. The TOFF_DELAY value determines the amount of time that elapses from the beginning of the off sequence until each channel's VOUT_EN pin is pulled low, thus disabling its DC/DC converter.

V_{OUT} Off Threshold Voltage

The MFR_VOUT_DISCHARGE_THRESHOLD command register allows the user to specify the OFF threshold that the output voltage must decay below before the channel can enter/re-enter the ON state. The OFF threshold voltage is specified by multiplying MFR_VOUT_DISCHARGE_THRESHOLD and VOUT_COMMAND. In the event that an output voltage has not decayed below its OFF threshold before attempting to enter the ON state, the channel will continue to be held off, the appropriate bit is set in the STATUS_MFR_SPECIFIC register, and the ALERTB pin will be asserted low. When the output voltage has decayed below its OFF threshold, the channel can enter the ON state.

Automatic Restart via MFR_RESTART_DELAY Command and CONTROL Pin

An automatic restart sequence can be initiated by driving the CONTROL pin to the off state for $>10\mu\text{s}$ and then releasing it. The automatic restart disables both V_{OUT_EN} pins that are mapped to a particular CONTROL pin for a time period = MFR_RESTART_DELAY and then starts all DC/DC Converters according to their respective TON_DELAYS. (see Figure 29). V_{OUT_EN} pins are mapped to one of the CONTROL pins by the MFR_CONFIG_LTC2972 command. This feature allows a host that is about to reset to restart the power in a controlled manner after it has recovered.

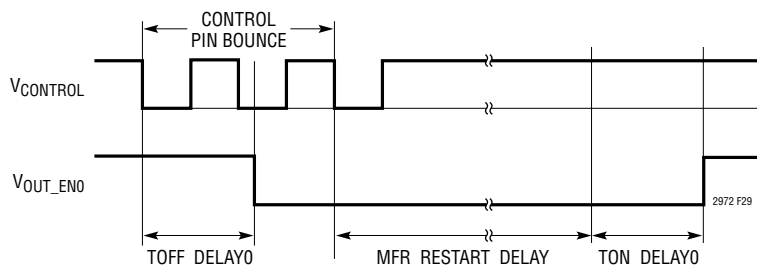

Figure 29. Off Sequence with Automatic Restart

APPLICATIONS INFORMATION

FAULT MANAGEMENT

Output Overvoltage and Undervoltage Faults

The high-speed voltage supervisor OV and UV fault thresholds are configured using the VOUT_OV_FAULT_LIMIT and VOUT_UV_FAULT_LIMIT commands, respectively. The VOUT_OV_FAULT_RESPONSE and VOUT_UV_FAULT_RESPONSE commands determine the responses to OV/UV faults. Fault responses can range from disabling the DC/DC converter immediately, waiting to see if the fault condition persists for some interval before disabling the DC/DC converter, or allowing the DC/DC converter to continue operating in spite of the fault. If a DC/DC converter is disabled, the LTC2972 can be configured to retry one to six times, retry continuously without limitation, or latch-off. The retry interval is specified using the MFR_RETRY_DELAY command. Latched faults are reset by toggling the CONTROL pin, using the OPERATION command, or removing and reapplying the bias voltage to the V_{IN_SNS} pin. All fault and warning conditions result in the ALERTB pin being asserted low and the corresponding bits being set in the status registers. The CLEAR_FAULTS command resets the contents of the status registers and de-asserts the ALERTB output.

Output Overvoltage, Undervoltage, and Overcurrent Warnings

OV, UV, and OC warning thresholds are processed by the LTC2972's ADC. These thresholds are set by the VOUT_OV_WARN_LIMIT, VOUT_UV_WARN_LIMIT, and IOUT_OC_WARN_LIMIT commands, respectively. Note that there is no I_{OUT} UC warning threshold. If a warning occurs, the corresponding bits are set in the status registers and the ALERTB output is asserted low. Note that a warning will never cause a V_{OUT_EN} output pin to disable a DC/DC converter.

Configuring the AUXFAULTB Output

The AUXFAULTB output may be used to indicate an output OV or UV fault. Use the MFR_CONFIG2_LTC2972 and MFR_CONFIG3_LTC2972 registers to configure the AUXFAULTB pin to assert low in response to VOUT_OV

or VOUT_UV fault conditions. The AUXFAULTB output will stop pulling low when the LTC2972 is commanded to re-enter the ON state following a faulted-off condition.

Figure 30 shows an application circuit where the AUXFAULTB output is used to trigger an SCR crowbar on the intermediate bus in order to protect the DC/DC converter's load from a catastrophic fault such as a stuck top gate. The stuck top gate causes an OV fault, which in turn causes the LTC2972 to pull AUXFAULTB low, thus de-asserting the ON input to the LTC4210 hot swap controller, which opens the switch Q1 that supplies the DC/DC converter input. In addition, when AUXFAULTB goes low it forces the S4010DS3 SCR device into the on-state via the 2N2907 PNP, thus quickly dropping the voltage on the V_{IN} input to the DC/DC converter, preventing the stuck top gate from damaging components supplied by this converter. Note that the V_{PWR} input to the LTC2972 bypasses switch Q1, keeping the LTC2972 fully powered throughout the above sequence.

Multi-Channel Fault Management

Multi-channel fault management is handled using the bidirectional FAULTB pins. Figure 31 illustrates the connections between channels and the FAULTB pins.

- The MFR_FAULTB_n_PROPAGATE command acts like a programmable switch that allows faulted_off conditions from a particular channel (PAGE) to propagate to either FAULTB output. The MFR_FAULTB_n_RESPONSE command controls similar switches on the inputs to each channel that allow any channel to shut down in response to any combination of the FAULTB pins. Channels responding to a FAULTB pin pulling low will attempt a new start sequence when the FAULTB pin in question is released by the faulted channel.
- A FAULTB pin can also be asserted low by an external driver in order to initiate an immediate off-sequence after a 10μs deglitch delay.

APPLICATIONS INFORMATION

INTERCONNECT BETWEEN MULTIPLE ADI POWER MANAGERS

Figure 32 shows how to interconnect the pins in a typical multi-LTC2972 array.

- All V_{IN_SNS} lines should be tied together in a star type connection at the point where V_{IN} is to be sensed. This will minimize timing errors for the case where the ON_OFF_CONFIG is configured to start the LTC2972 based on V_{IN} and ignore the $CONTROL$ line and the $OPERATION$ command. In multi-part applications that are sensitive to timing differences, it is recommended that the Vin_share_enable bit of the $MFR_CONFIG_ALL_LTC2972$ register be set high in order to allow $SHARE_CLK$ to synchronize on/off sequencing in response to the VIN_ON and VIN_OFF thresholds.
- Connecting all $AUXFAULTB$ lines together will allow selected faults on any DC/DC converter's output in the array to shut off a common input switch.
- $ALERTB$ is typically one line in an array of PMBus converters. The LTC2972 allows a rich combination of faults and warnings to be propagated to the $ALERTB$ pin.
- $WDI/RESETB$ can be used to put the LTC2972 in the power-on reset state. Pull $WDI/RESETB$ low for at least t_{RESETB} to enter this state.
- The $FAULTB$ lines can be connected together to create fault dependencies. Figure 32 shows a configuration where a fault on any $FAULTB$ will pull all others low. This is useful for arrays where it is desired to abort a startup sequence in the event any channel does not come up (see Figure 33).
- $PWRGD$ reflects the status of the outputs that are mapped to it by the MFR_PWRGD_EN command. Figure 32 shows all the $PWRGD$ pins connected together, but any combination may be used.

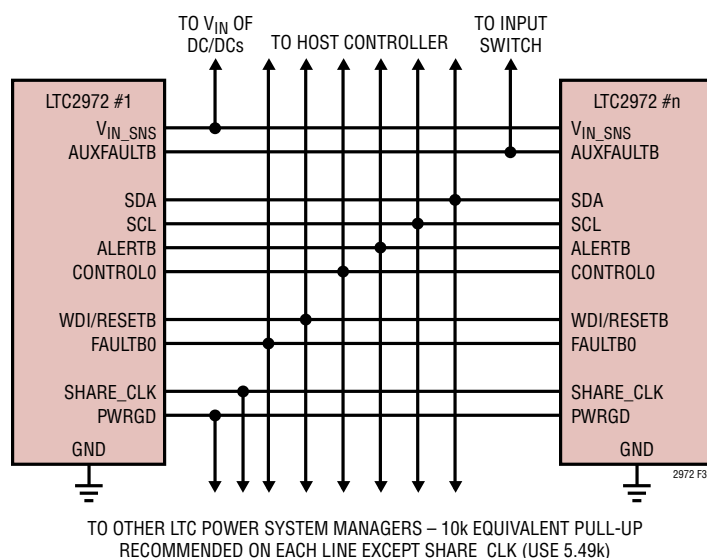

Figure 32. Typical Connections Between Multiple ADI Power System Managers

APPLICATIONS INFORMATION

$$R10 = \frac{R20 \cdot V_{FB}}{V_{DC(NOM)} - I_{FB} \cdot R20 - V_{FB}} \quad (1)$$

2. Solve for the value of R30 that yields the maximum required DC/DC converter output voltage $V_{DC(MAX)}$.

When V_{DAC0} is at 0V, the output of the DC/DC converter is at its maximum voltage.

$$R30 \leq \frac{R20 \cdot V_{FB}}{V_{DC(MAX)} - V_{DC(NOM)}} \quad (2)$$

3. Solve for the minimum value of V_{DAC0} that's needed to yield the minimum required DC/DC converter output voltage $V_{DC(MIN)}$.

The DAC has two full-scale settings, 1.38V and 2.65V. In order to select the appropriate full-scale setting, calculate the minimum required V_{FS_VDAC} output voltage:

$$V_{FS_VDAC} > (V_{DC(NOM)} - V_{DC(MIN)}) \cdot \frac{R30}{R20} + V_{FB} \quad (3)$$

4. Re-calculate the minimum, nominal, and maximum DC/DC converter output voltages and the resulting margining resolution.

$$V_{DC(NOM)} = V_{FB} \cdot \left(1 + \frac{R20}{R10}\right) + I_{FB} \cdot R20 \quad (4)$$

$$V_{DC(MIN)} = V_{DC(NOM)} - \frac{R20}{R30} \cdot (V_{FS_VDAC} - V_{FB}) \quad (5)$$

$$V_{DC(MAX)} = V_{DC(NOM)} + \frac{R20}{R30} \cdot V_{FB} \quad (6)$$

$$V_{RES} = \frac{R20}{R30} \cdot \frac{V_{FS_VDAC}}{1023} \text{ V/DAC LSB} \quad (7)$$

Trimming and Margining DC/DC Converters with a TRIM Pin

Figure 35 illustrates a typical application circuit for trimming/margining the output voltage of a DC/DC converter with a TRIM Pin. The LTC2972's V_{DAC0} pin connects to the TRIM pin through resistor R30. For this configuration,

set the DAC polarity bit `Mfr_config_dac_pol` in `MFR_CONFIG_LTC2972` to 1.

DC/DC converters with a TRIM pin may be margined high or low by connecting an external resistor between the TRIM pin and either the V_{SENSEP} or V_{SENSEM} pin. The relationships between these resistors and the $\Delta\%$ change in the output voltage of the DC/DC converter are typically expressed as:

$$R_{TRIM_DOWN} = \frac{R_{TRIM} \cdot 50}{\Delta_{DOWN}\%} - R_{TRIM} \quad (8)$$

$$R_{TRIM_UP} = R_{TRIM} \cdot \left[\frac{V_{DC} \cdot (100 + \Delta_{UP}\%)}{2 \cdot V_{REF} \cdot \Delta_{UP}\%} - \left(\frac{50}{\Delta_{UP}\%} \right) - 1 \right] \quad (9)$$

where R_{TRIM} is the resistance looking into the TRIM pin, V_{REF} is the TRIM pin's open-circuit output voltage and V_{DC} is the DC/DC converter's nominal output voltage. $\Delta_{UP}\%$ and $\Delta_{DOWN}\%$ denote the percentage change in the converter's output voltage when margining up or down, respectively.

Two-Step Resistor and DAC Full-Scale Voltage Selection Procedure for DC/DC Converters with a TRIM Pin

The following two-step procedure should be used to calculate the resistor value for R30 and the required full-scale DAC voltage (refer to Figure 35).

1. Solve for R30:

$$R30 \leq R_{TRIM} \cdot \left(\frac{50 - \Delta_{DOWN}\%}{\Delta_{DOWN}\%} \right) \quad (10)$$

2. Calculate the maximum required output voltage for V_{DAC0} :

$$V_{DAC0} \geq \left(1 + \frac{\Delta_{UP}\%}{\Delta_{DOWN}\%} \right) \cdot V_{REF} \quad (11)$$

Note: Not all DC/DC converters follow these trim equations, especially newer bricks. Consult ADI Field Application Engineering.

APPLICATIONS INFORMATION

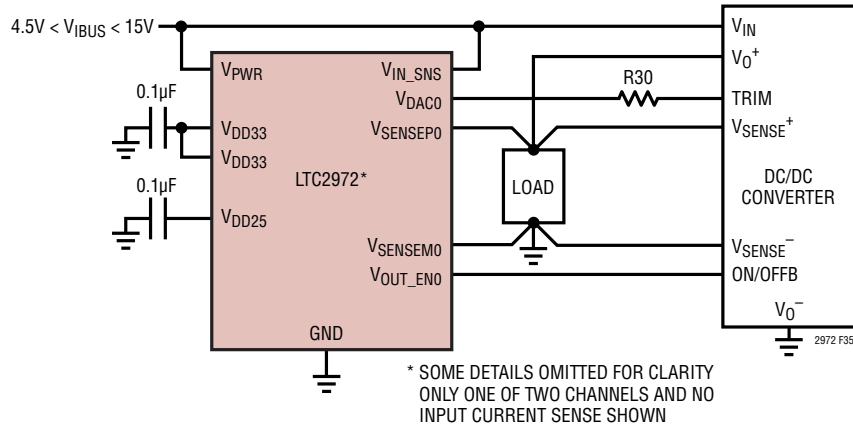

Figure 35. Application Circuit for DC/DC Converters with Trim Pin

Measuring Output with a Sense Resistor

A circuit for measuring current with a sense resistor is shown in Figure 36. The balanced filter rejects both common mode and differential mode noise from the output of the DC/DC converter. The filter is placed directly across the sense resistor in series with the DC/DC converter's inductor. Note that the current sense inputs must be limited to less than 6V with respect to ground. Select R_{CM} and C_{CM} such that the filter's corner frequency is $< 1/10$ the DC/DC converter's switching frequency. This will result in a current sense waveform that offers a good compromise between the voltage ripple and the delay through the filter. A value $1k\Omega$ for R_{CM} is suggested in order to minimize gain errors due to the current sense inputs' internal resistance.

Measuring Output with Inductor DCR

Figure 37 shows the circuit for applications that require DCR current sense. A second order R-C filter is required in these applications in order to minimize the ripple voltage seen at the current sense inputs. A value of $1k\Omega$ is suggested for R_{CM1} and R_{CM2} in order to minimize gain errors due the current sense inputs' internal resistance. C_{CM1} should be selected to provide cancellation of the zero created by the DCR and inductance, i.e. $C_{CM1} = L/(DCR \cdot R_{CM1})$. C_{CM2} should be selected to provide a second stage corner frequency at $< 1/10$ of the DC/DC converter's switching frequency. In addition, C_{CM2} needs to be much smaller than C_{CM1} in order to prevent significant loading of the filter's first stage.

Single Phase Design Example

As a design example for a DCR current sense application, assume $L = 2.2\mu H$, $DCR = 10m\Omega$, and $F_{SW} = 500kHz$.

Let $R_{CM1} = 1k\Omega$ and solve for C_{CM1} :

$$C_{CM1} \geq \frac{2.2\mu H}{10m\Omega \cdot 1k\Omega} = 220nF$$

Let $R_{CM2} = 1k\Omega$. In order to get a second pole at $F_{SW}/10 = 50kHz$:

$$C_{CM2} \cong \frac{1}{2\pi \cdot 50kHz \cdot 1k\Omega} = 3.18nF$$

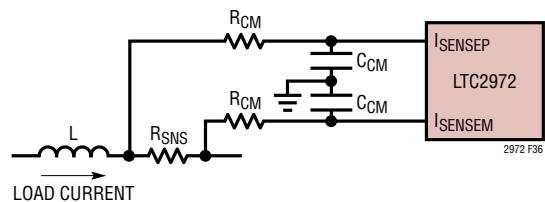

Figure 36. Sense Resistor Current Sensing Circuits

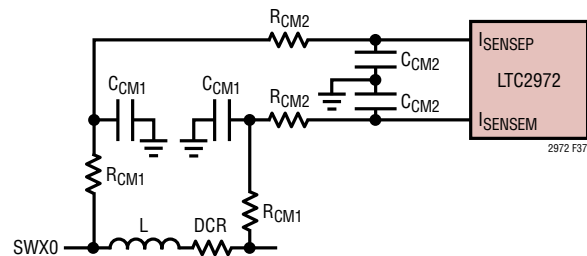

Figure 37. DCR Current Sensing Circuits

APPLICATIONS INFORMATION

Let $C_{CM2} = 3.3nF$. Note that since C_{CM2} is much less than C_{CM1} the loading effects of the second stage filter on the matched first stage are not significant. Consequently, the delay time constant through the filter for the current sense waveform will be approximately $3\mu s$.

Measuring Multiphase Currents

For current sense applications with more than one phase, R-C averaging may be employed. Figure 38 shows an example of this approach for a 3-phase system with DCR current sensing. The current sense waveforms are averaged together prior to being applied to the second stage of the filter consisting of R_{CM2} and C_{CM2} . Because the R_{CM1} resistors for the three phases are in parallel, the value of R_{CM1} must be multiplied by the number of phases. Also note that since the DCRs are effectively in parallel, the value for $I_{OUT_CAL_GAIN}$ will be equal to the inductor's DCR divided by the number of phases. Care should be taken in the layout of the multiphase inductors to keep the PCB trace resistance from the DC side of each inductor to the summing node balanced in order to provide the most accurate results.

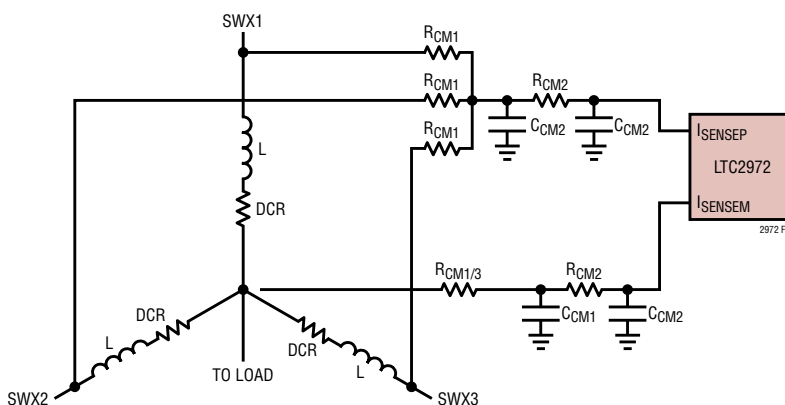

Figure 38. Multiphase DCR Current Sensing Circuits

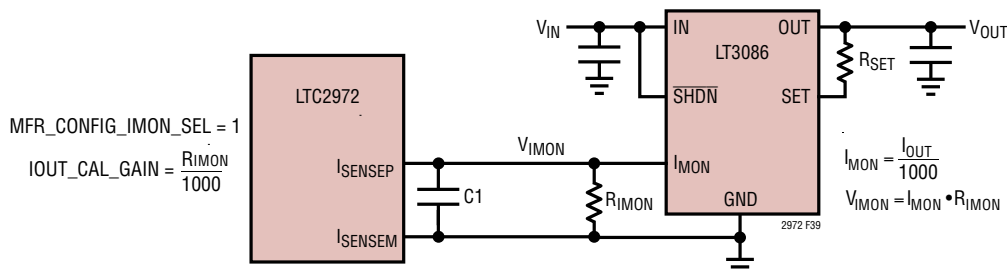

Figure 39. IMON Current Sensing

Measuring Output Current in Buffered IMON Telemetry Mode

The LTC2972 can interface to power supplies that output a signal proportional to their internally measured output current by setting $Mfr_config_imon = 1$. This mode increases the I_{SENSE} input range from $\pm 170mV$ to $-0.1V$ to $6V$. Regulators whose IMON pin outputs a current proportional to the average load current will require a resistor to convert this current to a voltage for digitizing by the LTC2972 ADC. The finite input impedance of I_{SENSE} input of the LTC2972 may affect the absolute accuracy of the load current measurement. Figure 39 shows the LTC2972 connecting to the IMON pin of the LT[®]3086 LDO regulator.

LT3086 IMON Design Example

The LT3086 will output a current equal to $I_{IMON} = I_{OUT}/1000$. If the desired V_{IMON} is $1.0V$ for a total output current of $I_{OUT} = 2.0A$ then $R_{IMON} = V_{IMON}/I_{IMON} = 500\Omega$ and $I_{OUT_CAL_GAIN}$ should be programmed to $500m\Omega$.

APPLICATIONS INFORMATION

Multiphase Design Example

Using the same values for inductance and DCR from the previous design example, the value for R_{CM1} will be $3k\Omega$ for a three phase DC/DC converter if C_{CM1} is left at $220nF$. Similarly, the value for $I_{OUT_CAL_GAIN}$ will be $DCR/3 = 3.33m\Omega$.

Anti-Aliasing Filter Considerations

Noisy environments require an anti-aliasing filter on the input to the LTC2972's ADC. The R-C circuit shown in Figure 40 is adequate for most situations. Keep $R_{40} = R_{50} \leq 200\Omega$ to minimize ADC gain errors, and select a value for capacitors C_{10} and C_{20} that doesn't add too much additional response time to the OV/UV supervisor, e.g. $\tau = 10\mu s$ ($R = 100\Omega$, $C = 0.10\mu F$).

Sensing Negative Voltages

Figure 41 shows the LTC2972 sensing a negative power supply (V_{EE}). The R_1/R_2 resistor divider translates the negative supply voltage to the LTC2972's $V_{SENSEM1}$ input while the $V_{SENSEP1}$ input is tied to the REFP pin which has a typical output voltage of 1.23V. The voltage divider should be configured in order to present about 0.5V to the voltage sense inputs when the negative supply reaches its $POWER_GOOD_ON$ threshold so that the current flowing out of the $V_{SENSEMn}$ pin is minimized to $\sim 1\mu A$. The relationship between the $POWER_GOOD_ON$ register value and the corresponding negative supply value can be expressed as:

$$V_{EE} = V_{REFP} - (READ_VOUT) \cdot \left(\frac{R_2}{R_1} + 1 \right) - 1\mu A \cdot R_2$$

where $READ_VOUT$ returns $V_{SENSEP} - V_{SENSEM}$

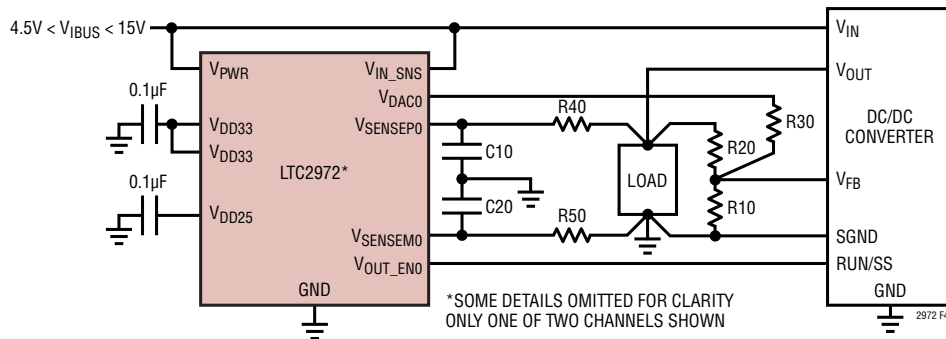

Figure 40. Anti-Aliasing Filter on V_{SENSE} Lines

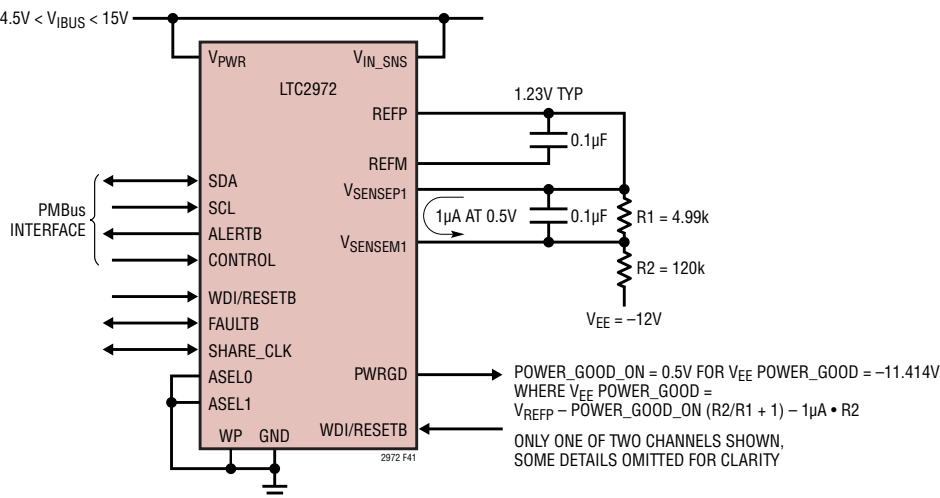

Figure 41. Sensing Negative Voltages

APPLICATIONS INFORMATION

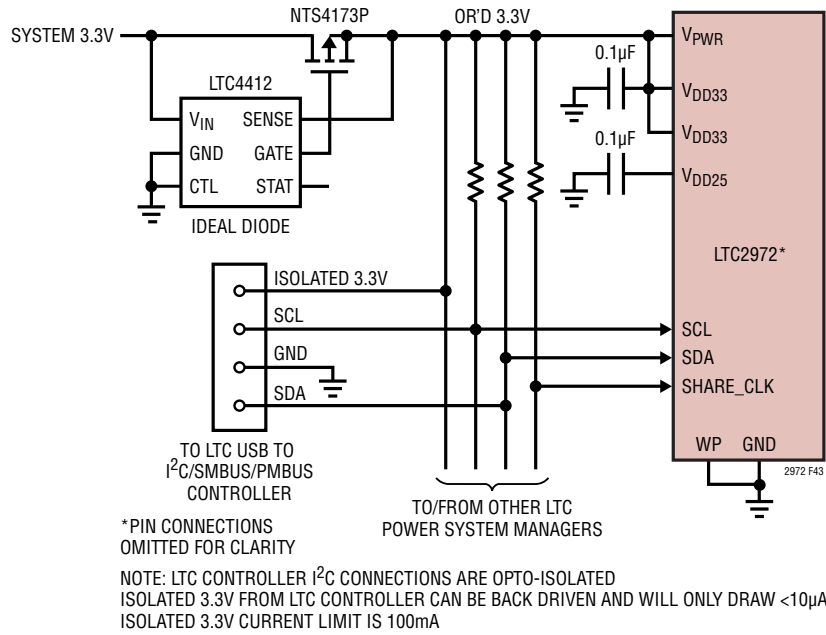

Figure 43. ADI Controller Connections When LTC2972 Is Powered Directly from 3.3V

APPLICATIONS INFORMATION

ACCURATE DCR TEMPERATURE COMPENSATION

Using the DC resistance of the inductor as a current shunt element has several advantages – no additional power loss, lower circuit complexity and cost. However, the strong temperature dependence of the inductor resistance and the difficulty in measuring the exact inductor core temperature introduce errors in the current measurement. For copper, a change of inductor temperature of only 1°C corresponds to approximately 0.39% current gain change. Figure 44 shows a sample layout using the integrated DC/DC converter LTC3601 (right) and its corresponding thermal image (left). The converter is providing 1.8V, 1.5A to the output load.

Heat dissipation in the inductor under high load conditions creates transient and steady state thermal gradients between the inductor and the temperature sensor, and the sensed temperature does not accurately represent the inductor core temperature. This temperature gradient is clearly visible in the thermal image of Figure 44. In addition, transient heating/cooling effects have to be accounted for in order to reduce the transient errors introduced when load current changes are faster than heat transfer time constants of the inductor. Both of these problems are addressed by introducing two additional parameters: the thermal resistance θ_{IS} from the inductor

core to the on-board temperature sensor, and the inductor thermal time constant τ . The thermal resistance θ_{IS} [°C/W], is used to calculate the steady state difference between the sensed temperature T_S and the internal inductor temperature T_I for a given power dissipated in the inductor P_I :

$$T_I - T_S = \theta_{IS} P_I = \theta_{IS} V_{DCR} I_{OUT} \quad (1.1)$$

The additional temperature rise is used for a more accurate estimate of the inductor DC resistance R_I :

$$R_I = R_0 (1 + \alpha [T_S - T_{REF} + \theta_{IS} V_{DCR} I_{OUT}]) \quad (1.2)$$

In these equations, V_{DCR} is the inductor DC voltage drop, I_{OUT} is the RMS value of the output current, R_0 is the inductor DC resistance at the reference temperature T_{REF} and α is the temperature coefficient of the resistance. Since most inductors are made of copper, we can expect a temperature coefficient close to $\alpha_{CU} = 3900\text{ppm}/^\circ\text{C}$. For a given α , the remaining parameters θ_{IS} and R_0 can be calibrated at a single temperature using only two load currents:

$$R_0 = \frac{(R_2 - R_1)(P_2 + P_1) - (R_2 + R_1)(P_2 - P_1)}{\alpha(T_2 - T_1)(P_2 + P_1) - (P_2 - P_1)(2 + \alpha[T_1 + T_2 - 2T_{REF}])} \quad (1.3)$$

$$\theta_{IS} = \frac{1}{\alpha R_0} \frac{\alpha(R_1 + R_2)(T_2 - T_1) - (R_2 - R_1)(2 + \alpha[T_1 + T_2 - 2T_{REF}])}{\alpha(T_2 - T_1)(P_2 + P_1) - (P_2 - P_1)(2 + \alpha[T_1 + T_2 - 2T_{REF}])} \quad (1.4)$$

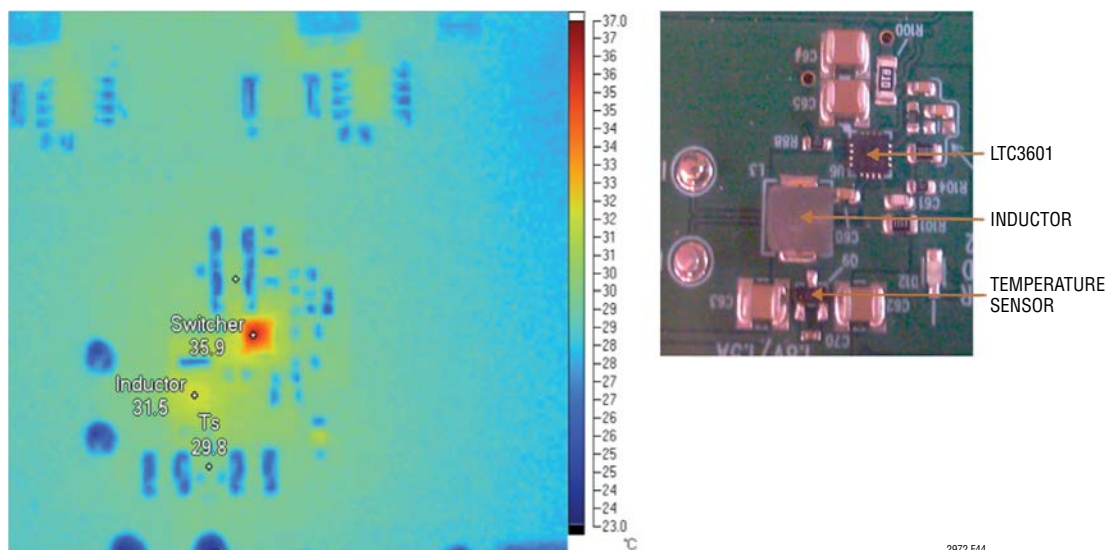

Figure 44. Thermal Image of a DC/DC Converter Showing the Difference Between the Actual Inductor Temperature and the Temperature Sensing Point

APPLICATIONS INFORMATION

The inductor resistance, $R_K = V_{DCR(K)}/I_{OUT(K)}$, power dissipation $P_K = V_{DCR(K)} I_{OUT(K)}$ and the sensed temperature T_K , ($K = 1, 2$) are recorded for each load current. To increase the accuracy in calculating θ_{IS} , the two load currents should be chosen around $I_1 = 10\%$ and $I_2 = 90\%$ of the current range of the system.

The inductor thermal time constant τ models the first order thermal response of the inductor and allows accurate DCR compensation during load transients. During a transition from low to high load current, the inductor resistance increases due to the self-heating. If we apply a single load step from the low current I_1 to the higher current I_2 , the voltage across the inductor will change instantaneously from $I_1 R_1$ to $I_2 R_1$ and then slowly approach $I_2 R_2$. Here R_1 is the steady state resistance at the given temperature and load current I_1 , and R_2 is the slightly higher DC resistance at I_2 , due to the inductor self-heating. Note that the electrical time constant $\tau_{EL} = L/R$ is several orders of magnitude shorter than the thermal one, and “instantaneous” is relative to the thermal time constant. The two settled regions give us the data sets (I_1, T_1, R_1, P_1) and (I_2, T_2, R_2, P_2) and the two-point calibration technique (1.3 – 1.4) is used to extract the steady-state parameters θ_{IS} and R_0 (given a previously characterized average α). The relative current error calculated using the steady-state expression (1.2) will peak immediately after the load step, and then decay to zero with the inductor thermal time constant τ .

$$\frac{\Delta I}{I}(t) = \alpha \theta_{IS} (V_2 \cdot I_2 - V_1 \cdot I_1) e^{-t/\tau} \quad (1.5)$$

The time constant τ is calculated from the slope of the best-fit line $y = \ln(\Delta I/I) = a_1 + a_2 t$:

$$\tau = -\frac{1}{a_2} \quad (1.6)$$

In summary, a single load current step is all that is needed to calibrate the DCR current measurement. The stable portions of the response give us the thermal resistance

θ_{IS} and nominal DC resistance R_0 , and the settling characteristic is used to measure the inductor thermal time constant τ .

To get the best performance, the temperature sensor has to be as close as possible to the inductor and away from other significant heat sources. For example in Figure 44, the bipolar sense transistor is close to the inductor and away from the switcher. Connecting the collector of the PNP to the local power ground plane assures good thermal contact to the inductor, while the base and emitter should be routed to the LTC2972 separately, and the base connected to the signal ground close to LTC2972.

LTpowerPlay: AN INTERACTIVE GUI FOR POWER MANAGERS

LTpowerPlay is a powerful Windows based development environment that supports Analog Devices power manager ICs with EEPROM, including the LTC2972. The software supports a variety of different tasks. You can use LTpowerPlay to evaluate Analog Devices ICs by connecting to a demo board system. LTpowerPlay can also be used in an offline mode (with no hardware present) in order to build a multi-chip configuration file that can be saved and re-loaded at a later time. LTpowerPlay provides unprecedented diagnostic and debug features. It becomes a valuable diagnostic tool during board bring-up to program the power management scheme in a system. LTpowerPlay utilizes Analog Devices' DC1613 USB-to-I²C/SMBus/PMBus Controller to communicate with one of many potential targets including the DC2022 demo board set, the DC1508 socketed programming board, or a customer target system. The software also provides an automatic update feature to keep the software current with the latest set of device drivers and documentation. A great deal of context sensitive help is available within LTpowerPlay along with several tutorial demos. Complete information is available at: ltpowerplay

APPLICATIONS INFORMATION

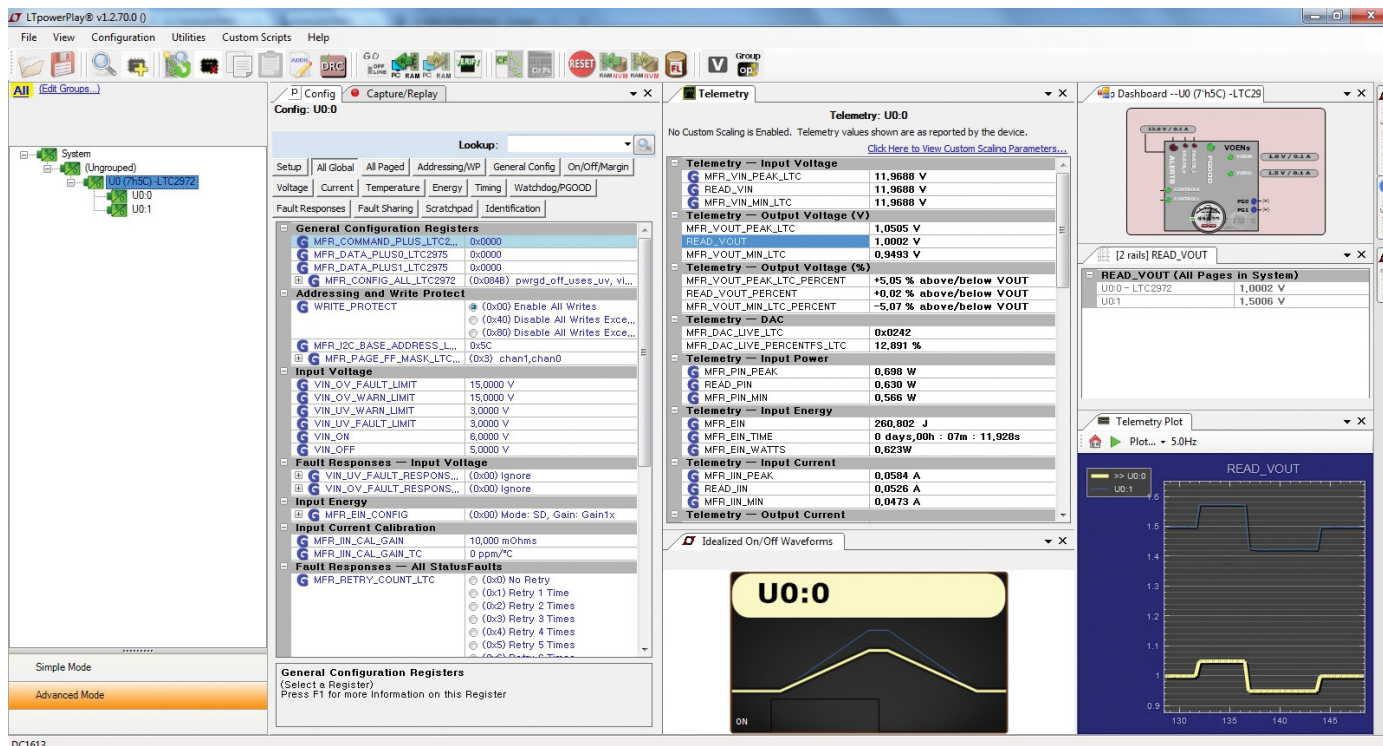

Figure 45. LTpowerPlay Snapshot

APPLICATIONS INFORMATION

PCB ASSEMBLY AND LAYOUT SUGGESTIONS

Bypass Capacitor Placement

The LTC2972 requires 0.1 μ F bypass capacitors between the V_{DD33} pins and GND, the V_{DD25} pin and GND, the REFP pin and REFM pin, and a 10nF capacitor between the $V_{IN_SNS_CAP}$ pin and GND. If the chip is being powered from the V_{PWR} input, then that pin should also be bypassed to GND by a 0.1 μ F capacitor. In order to be effective, these capacitors should be made of a high quality ceramic dielectric such as X5R or X7R and be placed as close to the chip as possible.

Exposed Pad Stencil Design

The LTC2972's package is thermally and electrically efficient. This is enabled by the exposed die attach pad on the under side of the package which must be soldered down to the PCB or mother board substrate. It is a good practice to minimize the presence of voids within the exposed pad inter-connection. Total elimination of voids is difficult, but the design of the exposed pad stencil is key. Figure 46 shows a suggested screen print pattern. The proposed stencil design enables out-gassing of the solder paste during reflow as well as regulating the finished solder thickness. See IPC7525A.

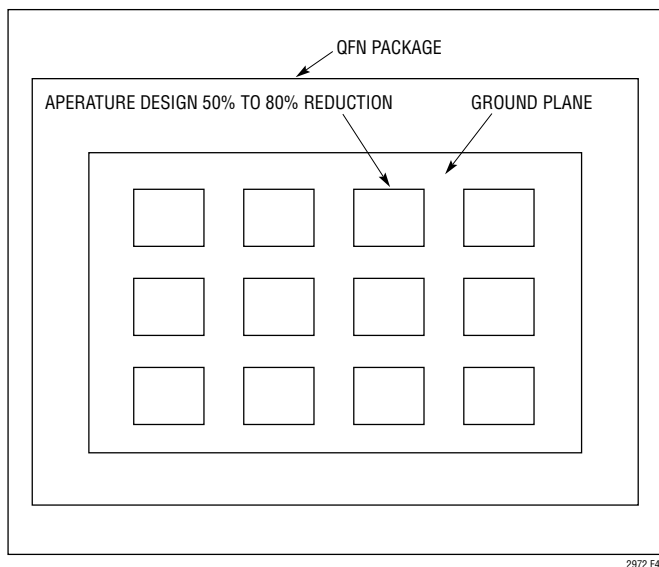

Figure 46. Suggested Screen Pattern for Die Attach Pad

PCB Board Layout

Mechanical stress on a PC board and soldering-induced stress can cause the LTC2972's reference voltage and the voltage drift to shift. A simple way to reduce the stress-related shifts is to mount the IC near the short edge of the PC board, or in a corner. The board acts as a stress boundary, or a region where the flexure of the board is minimal.

The LTC2972's READ_IIN input current sense amplifier has very low offsets enabling accurate current, power, and energy readings. PC Board routing to current sense inputs may create a thermal voltage offset if differential routing paths cross dissimilar metal boundaries in the presence of a thermal gradient. To minimize thermal voltages, route differential current sense inputs as close together as possible, and minimize vias. If vias are necessary, make sure to place both positive and negative current sense path vias are close together to minimize the temperature difference.

Unused ADC Sense Inputs

Connect all unused ADC sense inputs ($V_{SENSEPN}$ or $V_{SENSEMN}$) to GND. In a system where the inputs are connected to removable cards and may be left floating in certain situations, connect the inputs to GND using 100k resistors. Place the 100k resistors before any filter components, as shown in Figure 47, to prevent loading of the filter.

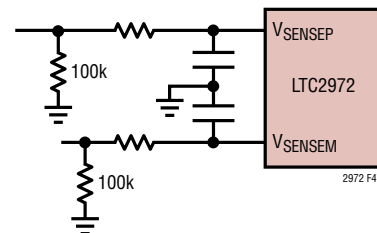

Figure 47. Connecting Unused Inputs to GND

APPLICATIONS INFORMATION

DESIGN CHECKLIST

I²C

The LTC2972 must be configured for a unique address.

The address select pins (ASEL_n) are tri-level; Check Table 3.

Check addresses for collision with other devices on the bus and any global addresses.

Output Enables

Use appropriate pull-up resistors on both V_{OUT_EN_n} pins.

Verify that the absolute maximum ratings of the V_{OUT_EN_n} pins are not exceeded.

V_{IN} Sense

No external resistive divider is required to sense V_{IN}; V_{IN_SNS} already has an internal calibrated divider.

Input Current Sense

Verify that I_{IN_SNSP} and I_{IN_SNSM} pins do not exceed absolute maximum ratings.

Add a 10nF capacitor to V_{IN_SNS_CAP}.

External Temperature Sense

Verify the PNP sense transistor is close to the inductor and away from other significant heat sources.

Verify the PNP sense transistor collector connects to a ground plane near the PNP, the emitter routes to the LTC2972, and the base connects to signal ground near the LTC2972.

Logic Signals

Verify the absolute maximum ratings of the digital pins (SCL, SDA, ALERTB, FAULTB_n, CONTROL_n, SHARE_CLK, WDI, ASEL_n, PWRGD) are not exceeded.

Connect all SHARE_CLK pins in the system together and pull-up to V_{DD33} with a 5.49k resistor.

Do not leave CONTROL_n pins floating. Pull up to V_{DDIO} with a 10k resistor.

Tie WDI/RESETB to V_{DD33} with a 10k resistor. Do not connect a capacitor to the WDI/RESETB pin.

Tie WP to either V_{DDIO} or GND. Do not leave floating.

Do not leave the FAULTB_n pins floating. Pull up to V_{DDIO} with a 10k resistor.

Unused Inputs

Connect all unused V_{SENSE_{Pn}}, V_{SENSE_{Mn}}, I_{SENSE_{Pn}}, I_{SENSE_{Mn}}, and T_{SENSE_n} pins to GND. Do not float unused inputs. Refer to Unused ADC Sense Inputs in the Applications Information section.

If not used, connect I_{IN_SNSP} and I_{IN_SNSM} pins to the V_{IN_SNS} pin.

DAC Outputs

Select appropriate resistor for desired margin range. Refer to the resistor selection tool in LTpowerPlay for assistance.

For a more complete list of design considerations and a schematic checklist, see the Design Checklist on the LTC2972 product page.

REVISION HISTORY

REV	DATE	DESCRIPTION	PAGE NUMBER
A	03/18	Typical Application: Removed junction dot between SHARE_CLK and WDI/RESETB.	112
B	01/19	Updated I _{IN} _ISENSE maximum specification.	6
C	04/21	Updated Typical Application.	1
		Removal of V _{DD33} and V _{DD25} output short circuit min/max specifications.	5
		Updated V _{DD33} and V _{DD25} pin descriptions.	16
		Updated section on Processing Commands and associated command tables.	22
		Corrected MFR_PADS type from 'R/W Word' to 'R Word'.	29, 68
		Updated text in Response When Part Is Busy section.	48
		Updated ALERTB behavior described in MFR_COMMON section.	73

